



LANDINI PARTS

**Pompe hydraulique - Hydraulic pump - Hydraulikpump -
Hydrauliekpompe - Bomba hidráulica**



	Part N°	OEM	Débit - Flow - Druck - Debiet - Flujo	Description Beschreibung Omschrijving Descripción
1114, 12500, 14500	31/566-236	3530246M91	11 + 8.5	Direction + blocage différentiel Steering + differential lock Lenkung + Differentialsperre Besturing + blokkage in differentieel Dirección + bloqueo diferencial





LANDINI PARTS

Embrayages - Clutches - Kupplungen - Koppelingen - Embragues

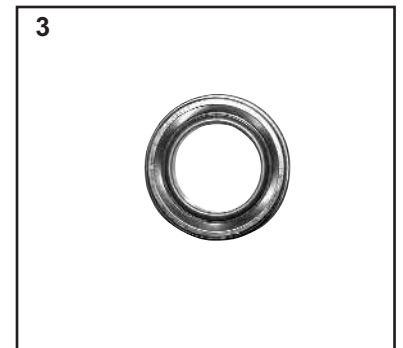
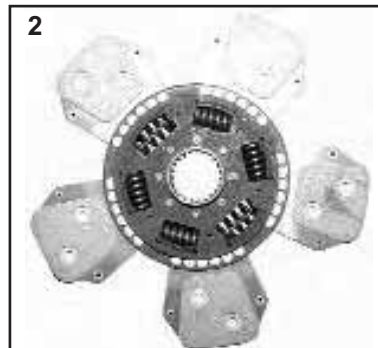
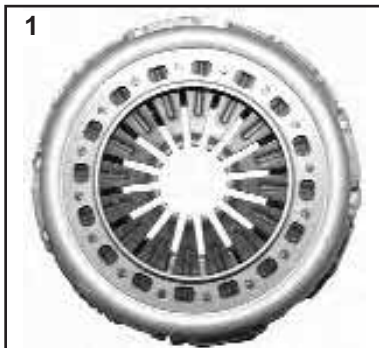

	1		2		3	
	Embrayage Clutch Kupplung Koppeling Embrague		Disque Plate Scheibe Rijplaat Disco		Butée de débrayage Release bearing Drucklager Drukklager Rodamiento	
Mythos 90, 100, 110 Mythos 105, 115 (Tier2)	330 DV	31/200-408 (3657986M91)	330	31/221-408 TC 23Z 44x48 (3657987M91)	31/231-408 (3549201M91)	

DV = Diaphragme, volant creux / Diaphragm, pot flywheel / Tellerfeder, vertieftes / Diafragma, geen vlak vliegwiel / Diafragma, volante rebajado
TC = Céramétique à ressort / Spring cera-metallic / Cerasinter-Belag, gefedert / Sintmetaal met veren / Ceramético con muelles





LANDINI PARTS

Embrayages - Clutches - Kupplungen - Koppelingen - Embragues

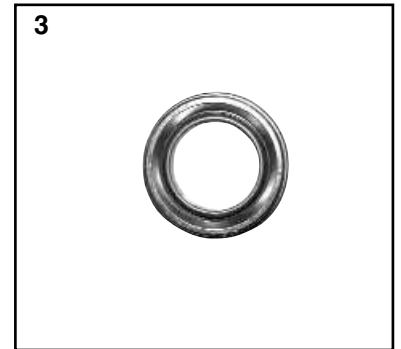
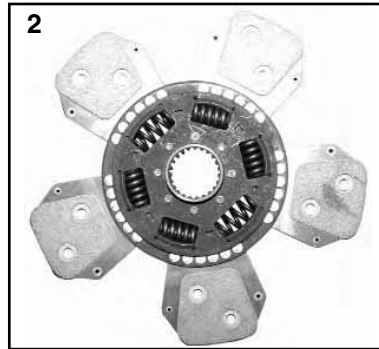
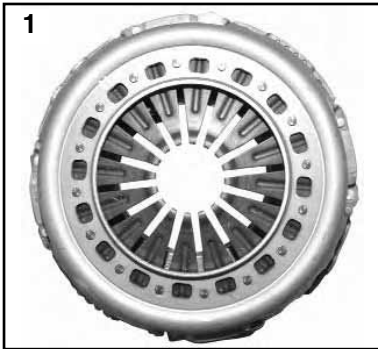

	1		2		3
	Embrayage Clutch Kupplung Koppeling Embrague		Disque Plate Scheibe Rijplaat Disco		Butée de débrayage Release bearing Drucklager Drukklager Rodamiento
Mythos 90, 100, 110 Mythos 105, 115 (Tier2)	330 DV	31/200-408 (3657987M91)	330	31/221-408 TC 23Z 44x48 (3540443M91)	31/231-408 (3306485M91)

DV = Diaphragme, volant creux / Diaphragm, pot flywheel / Tellerfeder, vertieftes / Diafragma, geen vlak vliegwiel / Diafragma, volante rebajado
TC = Céramétique à ressort / Spring cera-metallic / Cerasinter-Belag, gefedert / Sintermetaal met veren / Ceramético con muelles









TRACPIECES

**PRODUCT
NEWS-SHEET**

**PAGE : N° 7480
DATE : 01/06**

LANDINI PARTS

Démarrreur avec réducteur - Starter motor with reducer - Anlasser mit Reduzierer -
Startmotor met reductie - Motore de arranque con reductor

	Parts N°	OEM		 A x B Z	
Power Farm 75, 85, 95, 105 Rex New F/GT/GE 75, 85, 95, 105	62/930-200	3667037M91	12V 3,0KW	3x127 Z10	192mm
					

Les références des pièces sont indicatives.
Nos pièces ne sont pas d'origine.

Part numbers are quoted for reference purposes only.
Our parts and accessories are not original.



"THE RELIABLE SERVICE"







TRACPIECES

**PRODUCT
NEWS-SHEET**

**PAGE : N° 7428
DATE : 07/05**

LANDINI PARTS

Amortisseur de torsion - Torsion damper - Torsiondämpfer - Torsiedemper -
Amortiguador de torsión

	Parts N°	Dimensions	
LEGEND I 105, 115, 130, 145, 165 Powershift	31/196-32 (3652970M91)	26Z 50,4 x 54,6	
LEGEND II 115, 120, 130, 140, 160, 180 Powershift			
MYTHOS 90, 100, 110 VISION 80, 90, 100 Powershift	31/196-33 (3684843M91)	16Z 31x 35	

Les références des pièces sont indicatives.
Nos pièces ne sont pas d'origine.

Part numbers are quoted for reference purposes only.
Our parts and accessories are not original.



"THE RELIABLE SERVICE"





LANDINI PARTS

Pont avant - front axle - Vorderachse - Vooras - Eje delantero

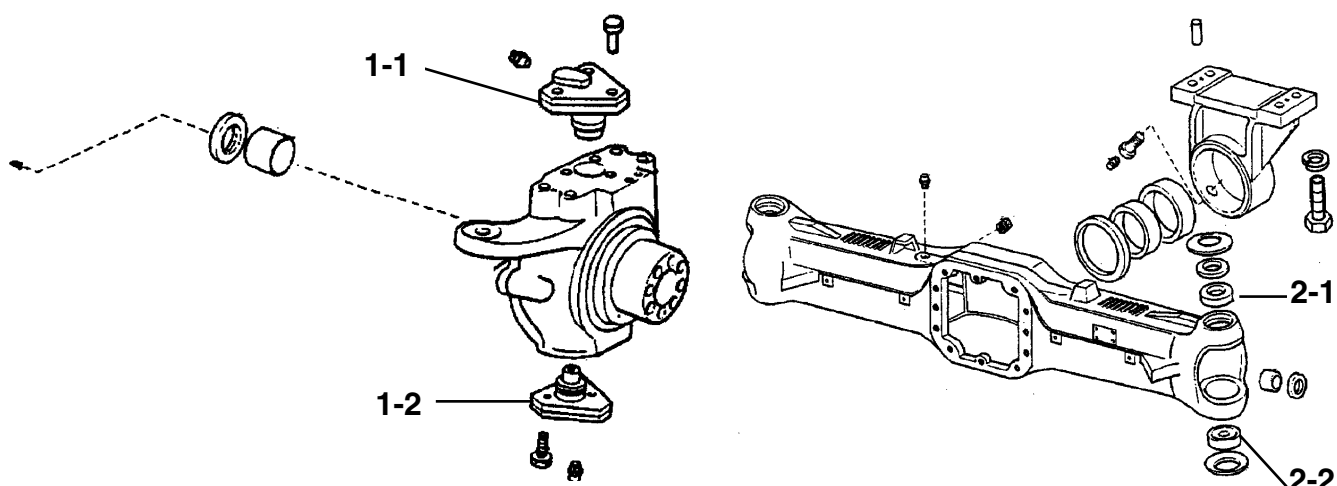

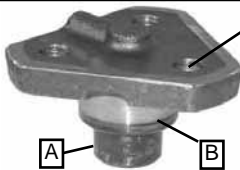
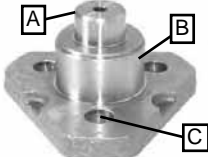
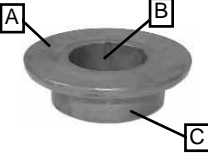
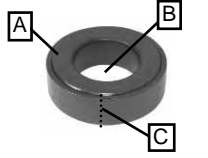
		1
Legend 105, 115, 130, 145	31/6450-58 (3541417M1) 1-1 A=Ø 35MM B=Ø 50MM C=Ø 16,50MM	
	31/6450-59 (3541419M1) 1-2 A=Ø 28MM B=Ø 50MM C=Ø 14,50MM	
	2	
	31/6451-80 (3541400M1) 2-1 A=Ø 75MM B=Ø 34,90MM C=Ø 52MM	
31/6451-81 (3541402M1) 2-2 A=Ø 52MM B=Ø 27,80MM C=Ø 16MM		



LANDINI PARTS

Embrayages - Clutches - Kupplungen - Koppelingen - Embragues

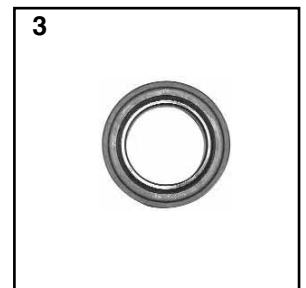
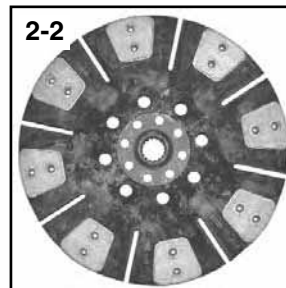
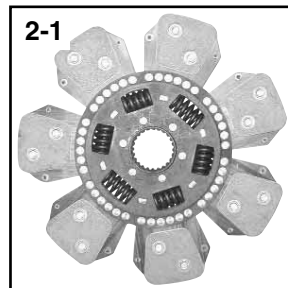
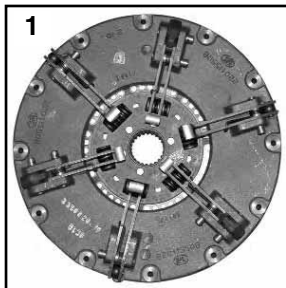

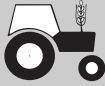
	1		2		3
	Embrayage Clucht Kupplung Koppeling Embrague		Disque Plate Scheibe Rijplaat Disco		Butée de débrayage Release bearing Drucklager Rodamenter Rodamiento
Legend techno 105, 115, 120, 130, 140, 145, 160, 165, 180	14" 350/350 TGU6 LUK	31/200-404L 3549179M91	14" 350	221-280 TC-LG-MH 24Z 48x52 3540443M91 2-1	31/231-82 3549201M91
			14" 350	31/212-404L UC-LM-LY 16Z 27x30 3541380M91 2-2	

LG = Friction d'avancement côté BV, monté / Main disc, transmission side, mounted / Fahrzscheibe getriebeseitig, eingebaut / Rijplaat aan versnellingsbakzijde, ingebouwd / Disco principal, montado en lado transmisión

LM = Friction prise de force côté moteur, libre / PTO disc, transmission side, mounted / Zapfwellenscheibe, getriebebesitig montiert / Losse aftakasplaat aan motorzijde / Disco TDF, lado motor, libre

LY = 8 paires de pastilles / 8 pairs of pads / 8 Paar Beläge / Met 8 paar pads / Con 8 pares de palas

MH = 7 paires de pastilles / 7 pairs of pads / 7 Paar Beläge / Met 7 paar pads / Con 7 pares de palas

UC = Céramétique fixe / Fixed cera-metallic / Cerasinter-Belag, ungefedert / Sintermetaal, vast, niet geveerd / Ceramético sin muelles

TC = Céramétique à ressorts / Spring cera-metallic / Cerasinter-Belag, gefedert / Sintermetaal met veren / Ceramético con muelles





LANDINI PARTS

Embrayages - Clutches - Kupplungen - Koppelingen - Embragues

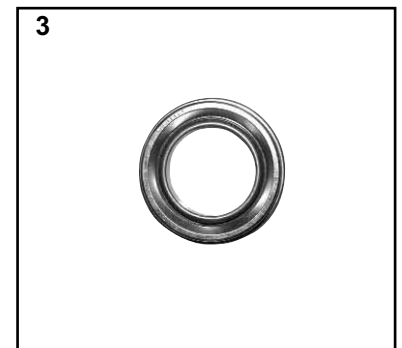
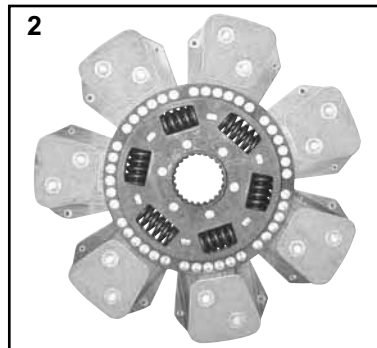
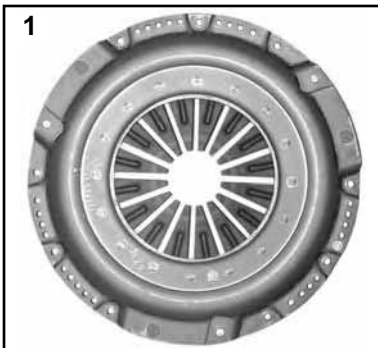

	1		2		3
	Embrayage Clucht Kupplung Koppeling Embrague		Disque Plate Scheibe Rijplaat Disco		Butée de débrayage Release bearing Drucklager Drukklager Rodamiento
Legend Top 105, 115, 120, 130, 140, 145, 160, 165, 180	14" 350 DV	31/200-280 3559802M91	14" 350	31/221-280 TC 24Z 48x52 3540443M91	31/231-280 3384863M93

DV = Diaphragme, volant creux / Diaphragm, pot flywheel / Tellerfeder, vertieftes / Diafragma, geen vlak vliegwiel / Diafragma, volante rebajado
TC = Céramétique à ressort / Spring cera-metallic / Cerasinter-Belag, gefedert / Sintermetaal met veren / Ceramético con muelles





LANDINI PARTS

EMBAYAGE - CLUTCH - KUPPLUNG - DRUKGROEP - EMBRAGUE

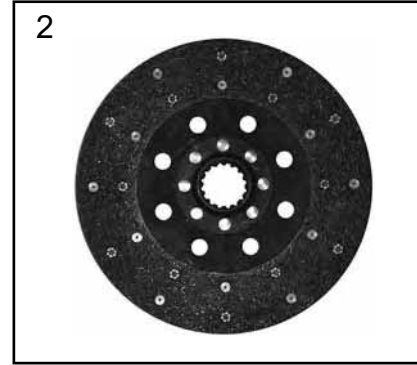
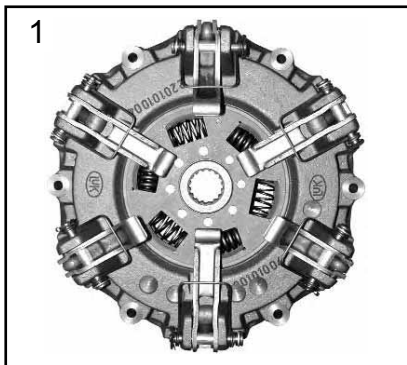

		Part N°	OEM	
Mistral 40, 45, 50 R / DT	1	31/200-273	4202165M91	6 Doigts Ø230 6 fingers Ø230 6 Hebel Ø230 6 drukvingers Ø230 6 palancas Ø230
	2	31/212-273	4202164M91	Disque friction, prise de force, côté moteur, libre PTO disc, engine side, loose Zapfwelle, motorseitig, lose Losse aftakasplaat aan motorzijde Disco PTO, suelto en el lado del motor





LANDINI PARTS

Filtres à air - Air filters - Luchtfilter - Luffilter - Filtros de aire



1



2

	1		2	
	Part N°	OEM	Part N°	OEM
Legend 130, 145, 165	60/161-167	3540422M91	60/162-167	3540423M91





LANDINI PARTS

Optique de phare - Front light - Reflector van koplamp -
Frontscheinwerfer - Faro delantero





	Désignation - Description - Omschrijving - Beschreibung - Descripción	Position - Position - Positie - Position - Posición	Part N°	OEM
Legend 105, 115, 130, 165	Conduite à droite - RH dip - Rechtsrijdend verkeer - Rechtsverkehr - Circulación por la drcha.	Droit - RH - Rechts - Rechts - Derecha	31/181-63	3551786M92
		Gauche - LH - Links - Links - Izquierda	31/181-64	3551787M92

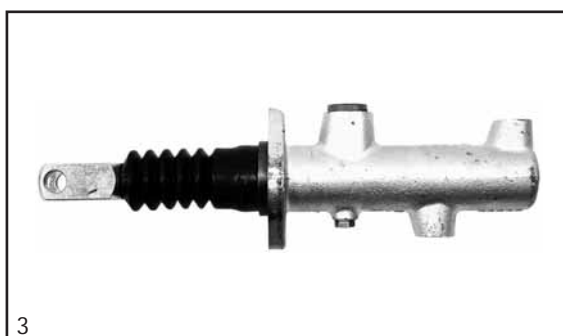
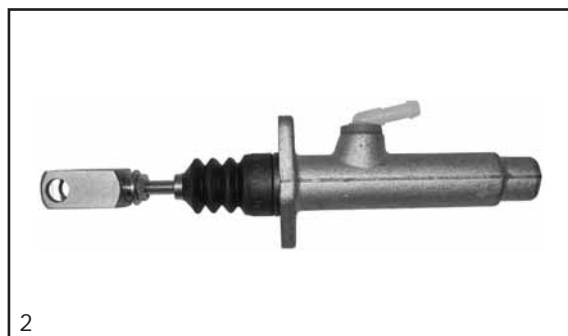
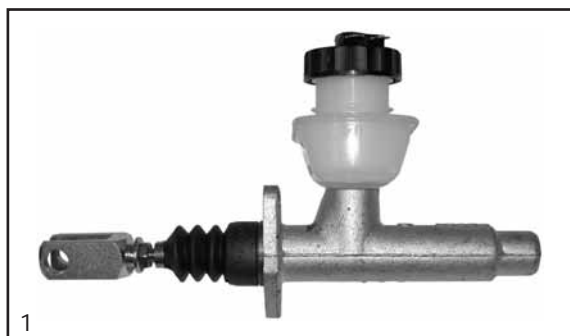

LANDINI PARTS

Maîtres cylindres - Master cylinders - Hoofdcilinders -
Geberzylinder - Cilindros principales







	Fig.	Ref.	OEM	Désignation - Description - Omschrijving - Beschreibung - Descripción
Legend 105, 115, 130, 145, 165	1	31/226-10	3558552M91	Embrayage - Clutch - Drukgroep - Kupplung - Embrague
Legend 105, 115, 130, 145	2	31/226-11	3555394M91	Embrayage - Clutch - Drukgroep - Kupplung - Embrague
Legend 105, 115, 130, 145, 165	3	31/410-40	3558716M92	Frein - Brake - Rem - Bremse - Freno



LANDINI PARTS

Tirants et accouplements de direction 4 roues motrices - Steering coupling 4 wheel drive - Spoorstangeind & scharniergewricht 4 WD traktoren - Spurstang & Kugelgelenk 4-Rad-Traktoren - Rótulas y acoples de dirección para tractores con doble tracción



	Fig.	Ref.	OEM			 mm
Legend105, 115, 130, 145 (avec suspension - with suspension - met vering - Mit Federung - con suspensión)	1	31/496-170	3541412M1	F 24 x 1.5 RH	265 mm	23.5 x 26.5
	2	31/495-170	3541414M1	F 24 x 1.5 RH	265 mm	23.5 x 26.5
	3	31/497-171	3541413M1	M 24 x 1.5 RH M 20 x 1.5 RH	210 mm	-
Legend 105, 115, 130, 145 (sans suspension - without suspension - zonder vering - Ohne Federung - sin suspensión)	4	31/495-239	3429701M1	F 24 x 1.5 RH	240 mm	23.5 x 26.5
	5	31/497-180	3426255M1	M 24 x 1.5 RH M 22 x 1.5 RH	210 mm	-
Legend 165	4	31/495-240	3764286M1	F 24 x 1.5 RH	240 mm	27 x 30
	5	31/497-180	3426255M1	M 24 x 1.5 RH M 22 x 1.5 RH	210 mm	-





LANDINI PARTS

Filtre hydraulique - Hydraulic filter - Hydrauliekfilter - Hydraulik-Filter - Filtro hidráulica

		OEM
5860, 6860, 7860, 8860, 5870, 6870, 7870, 8870, 6880, 7880, 8880, 9880, Série Advantage Serie, Série Blizzard Serie	60/641-26	3530223M92



pompes hydrauliques - hydraulic pumps - hydrauliek pompen -
Hydraulikpumpen - Bombas hidráulicas







			OEM
10000, 13000	1	69/566-102	3302501M92
Legend 105, 115, 130, 145, 165	2	69/565-85 0510767032	3552261M91



LANDINI PARTS

Tirants et accouplements de direction 4 roues motrices - Steering coupling 4 wheel drive -
Spoorstangeind & scharniergewricht 4 WD tractoren - Spurstang & Kugelgelenk
4-Rad-Traktoren - Rótulas y acoples de direccón para tractores con doble tracci3n



			OEM			
Legend 105, 115, 130, 145	1	31/496-170	3541412M1	F 24 x 1.5 RH	265 mm	23.5 x 26.5
	2	31/495-170	3541414M1	F 24 x 1.5 RH	265 mm	23.5 x 26.5
	3	31/497-171	3541413M1	M 24 x 1.5 RH M 20 x 1.5 RH	210 mm	

Maître cylindre et cylindre récepteur de frein - Master & slave brake cylinders -
Hoofd en ontvangstcilinder (remmen) - Hauptbremszylinder und Nehmerzylinder -
Cilindro principal y cilindro receptor (freno)



	1	2
Advantage 55, 60, 65, 75, 85 (F, FP, LP, GTP, GE, L, GL) 55V, 60V, 65V, 75V, Globus 50, 60, 70, Legend 105, 115, 130, 145	31/413-25 (3537812M91)	31/410-30 (3537810M91)

Stabilisateur - Stabiliser - Stabilisator - Stabilisator - Estabilizador



		OEM
10000, 12500, 13000, 14500, Legend 105, 115, 130, 145, 165	31/740-47	3304616M91

Les références des pièces sont indicatives.
Nos pièces ne sont pas d'origine.

Part numbers are quoted for reference purposes only.
Our parts and accessories are not original.



TRACPIECES

bepco tractor parts

PRODUCT NEWS-SHEET

PAGE : N° 7072

DATE : 01/2000

LANDINI PARTS

Fusée
Spindle
Achsschenkel
Fusee
Mangueta

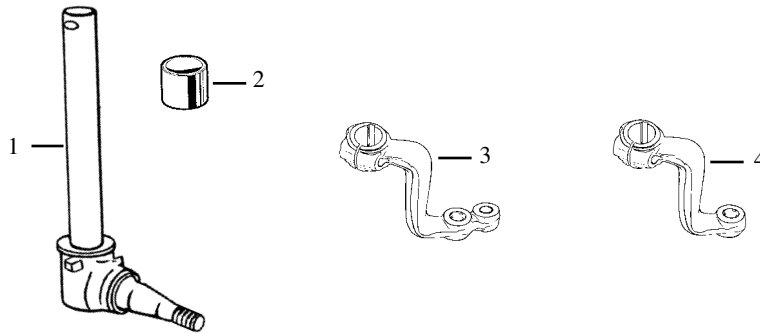

	Fig. Fig. Abb. Afb. Figura	Réf. Ref. Bestell-Nr. Bestel Nr. Ref.	OEM	Description Description Beschreibung Omschrijving Descripción
5500, 5830, 5840	1	31/470-37	1424579M91	Gauche / LH / Links / Links / Izqda. ou / or / oder / of / o Droite / RH / Rechts / Rechts / Dcha.
6500, 7500, 8500 6550, 7550, 8550 6830, 7830, 8830		31/470-38	1424578M91	
5500, 5830, 5840 6500, 7500, 8500 6550, 7550, 8550 6830, 7830, 8830	2	31/477-39	975208M2	Bague / Seal / Ring / Keerring / Retén
"60", "70", "80", "Blizzard"	3	31/480-19	1424974M2	Levier gauche, fusée Ø 38mm (avec direction assistée) Left lever, Ø 38mm spindle (with power steering) Lenkhebel links, Achsschenkel Ø 38mm (mit Lenkhilfe) Hendel links, fusee Ø 38mm (met Stuurbekrachting) Palanca izqda, mangueta Ø 38mm (con dirección asistida)
	4	31/480-20	1424584M2	Levier droit, fusée Ø 38mm Right lever, Ø 38mm spindle Lenkhebel rechts, Achsschenkel Ø 38mm Hendel rechts, fusee Ø 38mm Palanca dcha, mangueta Ø 38mm

Flotteur
Sender unit
Tankschwimmer
Tankvlotter
Flotador



31/172-28

(3530230M92)



Séries / Series / Serien / Series / Series
"60", "70", "Blizzard"

Les références des pièces sont indicatives.
Nos pièces ne sont pas d'origine.



"THE RELIABLE SERVICE"



Part numbers are quoted for reference purposes only.
Our parts and accessories are not original.

LANDINI PARTS

Croisillons
Universal joint
Kreuzstück
Kruisstuk
Cruceta

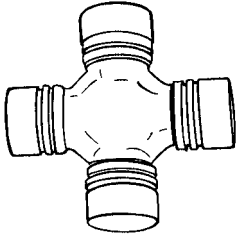

	Réf. Ref. Bestell-Nr. Bestel Nr. Ref.	OEM	Ø	
	4530V, 4560V, 5530V, 5560V, 6030V, 6530V, 6560V	31/6403-21	3427406M1	Ø 23,8 x 62,6
	5530F, 5560F/L, 5850, 5870, 6030L, 6530F/L, 6870, 6880, 7530F/L, 7560F/L, 8530F/L, 8560F/L	31/6403-22	3310490M91 3427346M91	Ø 27 x 74,6
	5500, 5530F, 5830, 5840, 6030, 6040, 6500, 6530F, 6550, 6830, 6840, 7500, 7550, 7830, 7860, 7870, 7880, 8500, 8550, 8830, 8860, 8870, 8880, 9080, 9880	31/6403-7	1423444M1 3310344M91	Ø 27 x 81,7
	9500, 10000, 10000S, 12500, 13000, 14500	31/6403-23	1429021M1	Ø 30,2 x 92,2



Echappement
Silencers
Schalldämpfer
Uitlaatdempers
Silenciosos

	Réf. Ref. Bestell-Nr. Bestel Nr. Ref.	OEM
10000, 13000	31/165-70	3301158M94
12500	31/165-111	1427504M95
14500	31/165-112	1427506M96



Contacteur combiné
Combined switch
Mehrfunktionsschalter
Gecombineerde schakelaar
Interruptor

31/958-9

(3554816M92)



Legend 105, 115, 130, 145, 165
 Globus 50, 60, 70

Les références des pièces sont indicatives.
 Nos pièces ne sont pas d'origine.

Part numbers are quoted for reference purposes only.
 Our parts and accessories are not original.



TRACPIECES

bepco tractor parts

PRODUCT NEWS-SHEET

PAGE : N° 7073

DATE : 01/2000

LANDINI PARTS

Démarreur
Starter motor
Anlasser
Startmotor
Motor de arranque

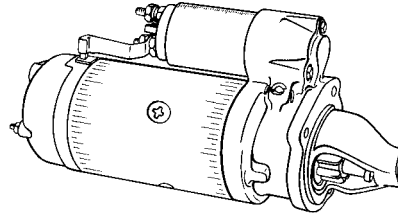

	Démarreur Starter motor Anlasser Startmotor Motore de arranque	Lanceur Drive ass. Ritzel Bendix Transmisión	Fixation Fitting Befestigung Bevestiging Fijación	Long. sortante Prominent length Länge ab Flansch Uitstekende lengte Longitud sobresaliente	Capacité Capacity Leistung Vermogen Capacidad	OEM
Moteurs/ Engines / Motoren / Motortypen / Motores 3A.152, AD3.152	62/930-4	10Z	3 Droite/RH R/R/Drcha	220	12V., 2,7KW	1680065M3
Moteurs/ Engines / Motoren / Motortypen / Motores 4A.203, AD4.20	62/930-10			254	12V., 3,5 KW	3597371M1
Moteurs/ Engines / Motoren / Motortypen / Motores A4.212, A4.236, A4.248, A6.354, A6.354-1, A6.354-4, T6.354-4 (certains / somes / Manche / Sommige / Unos)	62/930-62		3 Gauche/LH L/L/Izqda	250	12V., 3,5 KW	3597372M1 1860093M2
"Legend"	62/930-38				3 Droite/RH R/R/Drcha	12V., 3 KW

Moteur d'essuie-glace
Wiper motor
Scheibenwischermotor
Ruitenwissermotor
Motor de limpiaparabrisas

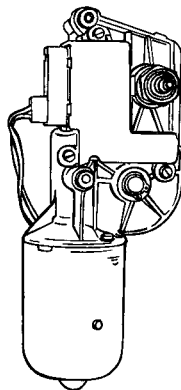

63/1980-24

(3559734M91)



Legend
105, 115, 130, 145, 165

Les références des pièces sont indicatives.
Nos pièces ne sont pas d'origine.



"THE RELIABLE SERVICE"



Part numbers are quoted for reference purposes only.
Our parts and accessories are not original.

LANDINI PARTS

Pompes hydrauliques
Hydraulic pumps
Hydraulikpumpen
Hydrauliek pompen
Bombas hidraulicas

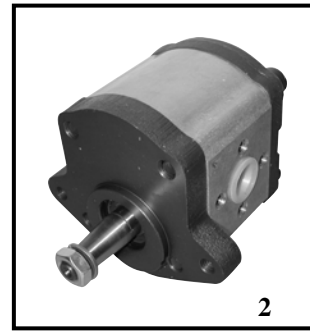
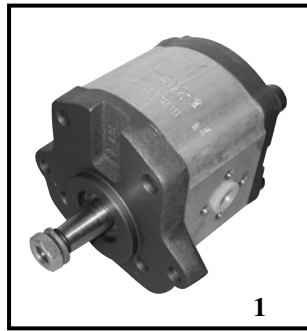

	Pompes hydrauliques Hydraulic pumps Hydraulikpumpen Hydrauliek pompen Bombas hidraulicas	Fig. Fig. Abb. Afb. Fig.	Débit (cc) Flow cc Druck (cc) Debiet cc Flujo cc.	Rotation Rotation Drehrichtung Draairichting Rotación	OEM
6530, 6860, 6870, 6880, 7860, 7870, 7880, 8860, 8880, 9880	69/565-52	1	11	Gauche / LH L / L / Izq	BH525339
5860, 5870, 6060, 6070	69/565-48	2	11	Droite / RH R / R / Dcha	BH525037

Pompes hydrauliques pour blocage du différentiel
Hydraulic pumps for differential lock
Hydraulikpumpen für Differentialsperre
Hydrauliek pompen voor Blokkage diferentiëel
Bombas hidraulicas

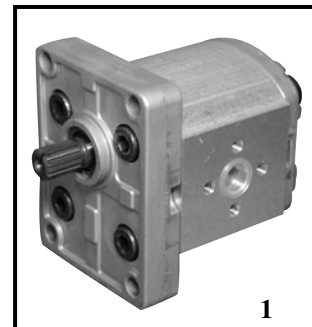

	Pompes hydrauliques Hydraulic pumps Hydraulikpumpen Hydrauliek pompen Bombas hidraulicas	Fig. Fig. Abb. Afb. Fig.	OEM
10000, 13000	69/566-5	1	3310317M91
12500, 14500	69/566-6	2	3300930M91

Les références des pièces sont indicatives.
 Nos pièces ne sont pas d'origine.

Part numbers are quoted for reference purposes only.
 Our parts and accessories are not original.

NOUVEAUTES - INFOS

JANVIER 1997

ADAPTABLE : LANDINI



Page LA-3

CABLES D'EMBRAYAGE

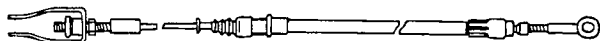

Ajouter :

- L.3301/290** - Commande d'avancement
(10000, 10000S, 13000)

Page LA-4

FREINS HYDRAULIQUES

Compléter :

- | | | |
|---------------------|---------------------|------------------|
| 1. M.1874957 | - Maître cylindre | 6550, 7550, 8550 |
| | Ø 17,8 | 10000, 12500 |
| 2. M.1810596 | - Jeu de réparation | 14500 |



ECHAPPEMENTS

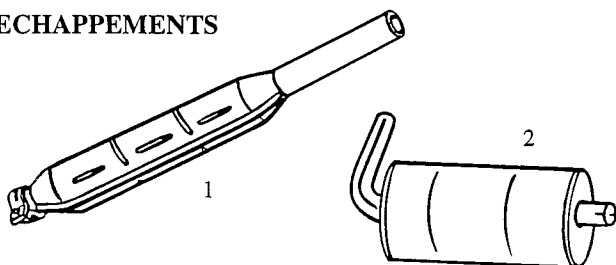

Ajouter :

1. **03530335M91** - Echappement vertical
(Ø emmanchure 55mm)
2. **03531689M91** - Echappement horizontal
(Tracteurs de fructiculture)

Montés aussi sur tracteurs "MASSEY-FERGUSON"

COLLECTEURS D'ECHAPPEMENT

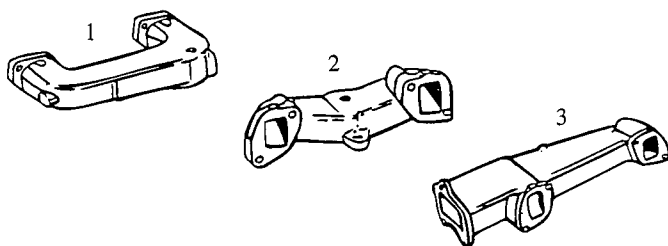

1. **30/37781341** - (AD3.152) coude 180°
(734874M1) MF.254, MF.254S, MF.353, 4500, 5500
- 30/37781571** - (AD3.152) coude 90°
(740221M1) MF.254, MF.254S, MF.353, 4500, 5500
2. **30/37781333** - 6500 (A4.212), 7500, 7530 (A4.236)
8500 (A4.248), MF.174, 184, 274, 194
3. **30/37781051** - 6550, 7550 (A4.236), 8550 (A4.248)
MF.274SK, 284S-4S, 294S-4S

COMMANDES DE POMPES

Page LA-7

Modifier comme suit :

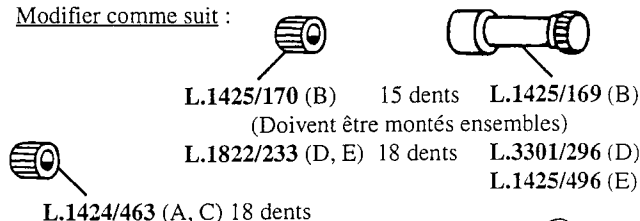

L.1425/170 (B) 15 dents **L.1425/169** (B)

(Doivent être montés ensembles)

L.1822/233 (D, E) 18 dents **L.3301/296** (D)

L.1425/496 (E)

L.1424/463 (A, C) 18 dents

L.828/724 Silentbloc (A, B, C)

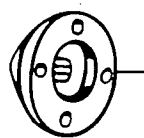

L.1424/502 4 trous / cône (A, F)

L.1424/368 4 trous / 18 can. (A, C)

L.1427/385 4 trous / 14 can. (B)

(L.1425/325)

L.1425/497 3 trous / 14 can. (D)

(A) 5500, 6500, 7500, 8500, 9500

(D) 10000, 13000

(B) 6550, 7550, 8550, 9500

(E) 12500, 14500

(C) 5830, 6830, 7830, 8830

(F) Moyeu conique



Page LA-9

STABILISATEURS SPECIAUX "LANDINI"

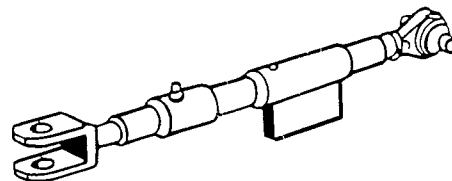

Ajouter :

L.3533/205 - 5860, 5870, 6860, 6870, 6880

L.3532/084 - 7860, 7870, 7880, 8860, 8870, 8880

POIGNEES DE PORTIERE

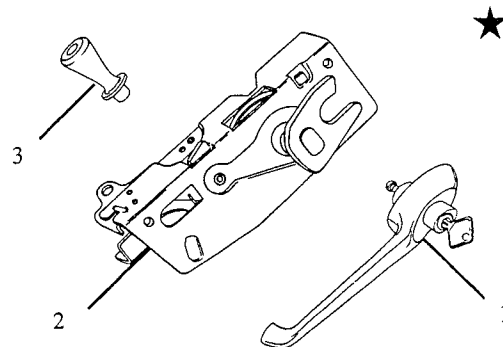

Tracteurs 6550, 7550, 8550, 6880, 7880, 8880, 9880, 10000, 13000

1. **30/3301856** - Poignée
2. **30/3301854** - Serrure (Porte gauche)
30/3301855 - Serrure (Porte droite)
3. **30/3301853** - Poignée

Non original replacements

(Ed.2) 04/97

**LES PIECES DETACHEES DE MOTEURS
SONT REPRISES A LA SECTION "PERKINS" (FASCICULE 2)**

LISTE DE CORRESPONDANCES, TRACTEURS "LANDINI" = TRACTEURS "MASSEY-FERGUSON"

MF. 154 = 5500	MF. 253 = 5830	MF. 294/S = 8550	MF. 383/S = 7870
MF. 154/S = 5530	MF. 254 = 5840	MF. 353 = 5860	MF. 387 = 7880
MF. 174 = 6500	MF. 263 = 6030	MF. 353/S = 5870	MF. 393 = 8860
MF. 174/S = 6530	MF. 273 = 6830	MF. 363 = 6060	MF. 393/S = 8870
MF. 184 = 7500	MF. 274/S = 6840	MF. 363/S = 6070	MF. 397 = 8880
MF. 184/S, 4S = 7530	MF. 283 = 7830	MF. 373 = 6860	MF. 1104 = 9500
MF. 194 = 8500	MF. 284/S = 7550	MF. 373/S = 6870	MF. 1014 = 10000
MF. 194/4S = 8530	MF. 293 = 8830	MF. 377 = 5880	MF. 1114 = 12500
MF. 234 = 5830	MF. 294 = 8500	MF. 383 = 7860	MF. 1134 = 14500

POMPES A EAU ET REPAIR KITS

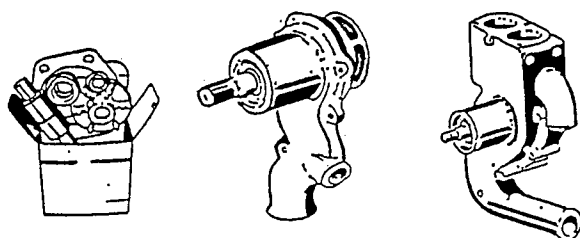

- P.50026 - 4000 (P3/TA)
- P.4131/2494 - 4500,5000
- R. kit: P.58293
- P.4131/2511 - R.50,6000,7000,6500 (4A.203)
- R. Kit: P.59140
- P.4131/2809 - 9500, (MF. 1104), 10000 (6A.354)
- (U5MW.0016)
- R. Kit: P.89007
- P.50023 - Sans poulie | Tract. avec moteurs
- P.4131/2487 - Avec poulie | 3.152, D3.152 (3 cyl.)
- P.58293 - Repair kit
- P.4131/2914 - Sans poulie | Tract. avec moteurs
- P.4131/2915 - Avec poulie | 4.212, 4.236, 4.248
- P.89034 - Repair kit | (4 cyl.)
- P.4131/3027 - Sans poulie | 10000S, 12500, 13000
- P.68575 - Repair kit | 14500, 16000, 16500
- (6.354-4)

DEMARREURS NEUFS

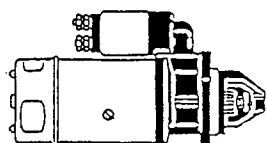

- * Moins chers que la réparation
- * Pas d'échange

- LU.26206 - Moteurs 3 cylindres
- LU.R/26264 - Moteurs 4.203, D4.203 (4 cyl.)
- LU.R/26271 - Moteurs 4.212, 4.236, 4.248 (4 cyl.)
- 6.354, 6.354-1, 6.354-4, T6.354-4
- (6 cyl.)

NOTE: Les pièces de rechange pour démarreurs "LUCAS" livrables sont détaillées à la page MF-12 du catalogue, fascicule 2

**POMPES D'ALIMENTATION
ET REPAIR KITS**



M.1850168
(0995260)

- P.2641/40F - (D) Pompe avec bol décanteur (2641406/408) (Mot. 3.152, D3.152 3 cyl.)
- P.2641/311 - (E) Pompe sans bol décanteur (2641A063, 2641712) (Mot. 3.152, D3.152 3 cyl.)
- P.2641/345 - (F) Mot. 4.203, D4.203 (4 cyl.) (2641A065)
- P.2641/465 - (H) Flasque 2 trous | Moteurs 4.212, 4.236
- (2641478)
- P.2641/709 - Flasque 4 trous | 4.248
- (2641725) Sorties parallèles (4 cyl.)
- P.2641/711 - Flasque 4 trous
- (2641728)
- P.2641/372 - (M) 9500, 10000
- (2641A064) (Mot. 6.354, 6.354-1)
- P.2641/719 - 10000S, 12500, 13000, 14500, 16000
- 16500 (Mot. 6.354-4, T6.354-4)

REPAIR KITS:

- P.2641/0042 - Pour pompes "AC", appl. (D), (E)
- P.2641/0045 - Pour pompes "AC", appl. (F), (M)
- P.2641/0050 - Pour pompes "AC", appl. (H)

ALTERNATEURS NEUFS (ET DYNAMO)

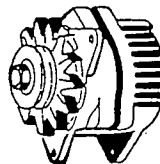

- * Sans échange
- * Capacités de 14V./33,34,45 et 55A.

- LU.24087 - Type "LUCAS" 14V./34A. | 6500-8550
- 510E.343 - Type "VALEO" 14V./45A. | et dérivés
- 432E.985 - Type "VALEO" 14V./33A.
- LU.23835 - Type "LUCAS" 14V./55A. | 10000, 12500
- 510E.344 - Type "VALEO" 14V./45A. | 14500 et dérivés.

NOTE: Régulateurs et jeux de balais, voir page "MF-12" du catalogue, fascicule 2.

- LU.22703 - Dynamo 12V., type "LUCAS" (28711B2) Suivant montages.

Non original replacements

FILTRES A HUILE ET A COMBUSTIBLE

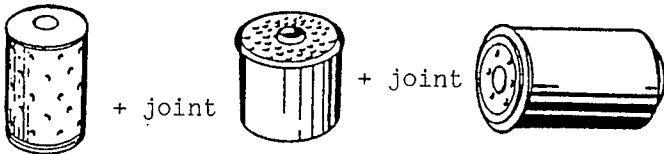

TRACTEUR	HUILE	MAZOUT
R.3000 (-8/62)	103	
R.3000	103	F.1007
R.50, R.4000, R.4500,		
R.6000 (1964)	103	1058
R.4500 (certains)	103	1004 et 1001
R.4500 (filtre vissé)	465	1087
R.4000, R.5000, R.7000	103	1087 et 1001
R.6000 (1970/-)	103	1087
R.9500, MF.1104	267	1087 ou 1193
5500, 5830 (3 cyl.)	103	1087
Idem, filtre vissé	465	1087
6500, 6530, 6550, 7500,		
8000	102T	1087
Idem, filtre vissé	599/AR	1087
7530, 7550, 7580, 7830,		
8500, 8550, 8830, 10000		
12500	267	1087
11500	267	1193
1300, 13500, 14500,	267	1087



7111-429 (Moteurs 3 et 4 cyl.)
7111-403 (Moteur 6 cyl. 6.354-1)
Autres pièces de filtre "C.A.V."
voir fascicule 1.

DURITES DU REFROIDISSEUR

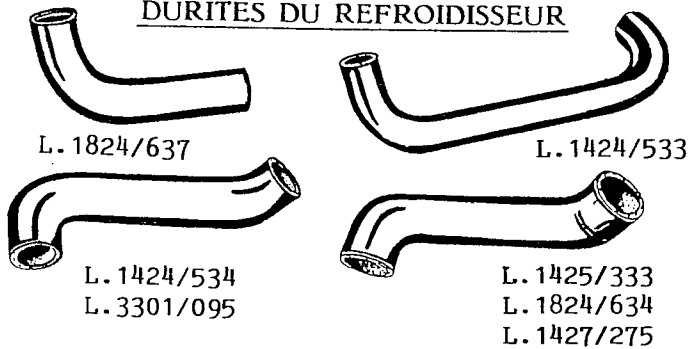

DURITE SUPERIEURE (RADIATEUR)
L.1824/633 - 5500, 6500, 7500, 8500, 5830, 6830, 7830, 8830
L.1427/274 - 6550, 7550, 8550
L.1822/671 - 9500
L.3301/097 - 10000
L.1425/332 - 12500, 14500

DURITE INFERIEURE (RADIATEUR)
L.1824/634 - 5500, 5830
L.1824/637 - 6500, 7500, 8500 (1ère série)
L.1424/533 - 6500, 7500, 8500, 6830, 7830, 8830
L.1427/275 - 6550, 7550, 8550
L.1424/534 - 9500 (UA.30857→)
L.3301/095 - 10000 (Mot. 6.354-1)
L.1425/333 - 10000 (Mot. 6.354-4), 12500, 14500

Suite au milieu de la colonne de droite

REFROIDISSEUR

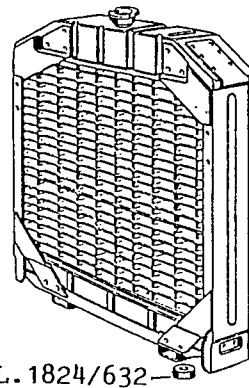

L.1824/627
Radiateur complet
(5500, 5830, 6500, 6830, 7500, 7830, 8500, 8830)



L.1824/628 - Bouchon

P.31419 - Robinet (1430870)

L.1824/632

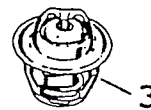
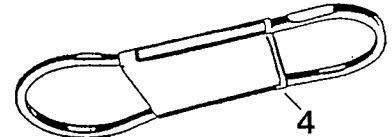
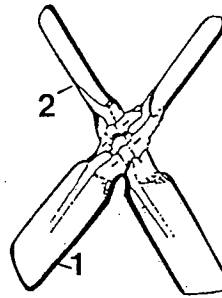

- 1. M.1884777 (963929) Ø 394 | 5500
- 2. M.1884738 (963930) Ø 394 | 5500
- 1. M.1885172 (894730) Ø 406 | 6500, 7500, 8500
- 2. M.1885173 (894729) Ø 406 | 6550, 7550, 8550
- 3. P.2485/645 - Mot. 3 cyl. 3.152, D3.152
- P.2485/659 - Mot. 4 cyl. 4.212, 4.236, 4.248
- P.2485/613 - Mot. 6 cyl. 6.354-1, 6.354-4
- 4. P.2612/418 (L = 1200 mm.) 3.152, D3.152
- P.2612/419 (L = 1215 mm.) | 4.212, 4.236
- P.2612/424 (L = 1290 mm.) | 4.248
- P.2614/166 | 6.354-1
- P.2614/169 | 6.354-4
- P.2614/173 | 6.354-4

DURITE POMPE A EAU (VERS MOTEUR)

P.3482/1422 - Mot. 3 cyl.
L.1824/636 - 6500, 7500, 8500
L.3482/5133 - 9500 (2ème série), 10000 (6.354-1)
L.3385/5114 - 10000 (6.354-4) 12500, 14500
L.3385/5121 - 12500, 14500

DURITE "BY-PASS" (SUR POMPE A EAU)

P.0202016 - Mot. 3 cyl.



NEZ D'INJECTEURS

- 30/2646607 (31990) - Mot. 3.152, 4.203
- 30/2646676 (26461311) - Mot. D3.152, D4.203
- 30/2646689 (26461317) - Mot. 4.212
- 30/2646690 (2645C.611) - Mot. 4.248
- 30/2646842 (2645C.609) - Mot. 4.236
- 30/2646679 - Mot. 6.354-1
- 30/2646844 (2645C.612) - Mot. 6.354-4
- 30/2646845 (26461304) - Mot. T6.354-4
- P.0920113 - Joint Ø 20,8 x 14,5
- P.0921173 - Joint Ø 21,1 x 10,0

Non original replacements

TRACTOMETRES

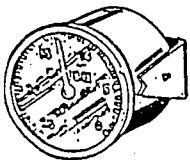

	TRANSMISSION	
	TRACTOMETRE	FLEXIBLE
5500, 6500, 7500, 8500	M. 1825115	M. 1423769K
6550, 7550, 8550	M. 1825115	-
5830, 6830, 7830, 8830	M. 1825115	M. 1423769K
10000, 12500, 13000, 14500	L. 1425/790	L. 1425/872
9500	-	L. 1423/262

ENTRAINEURS:

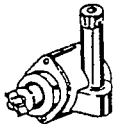

P. 2758/348 - Mot. 3 et 4 cylindres (2758346)
 P. 2758/314 - 9500, 10000, 12500, 14500

CONTACTEURS DIVERS

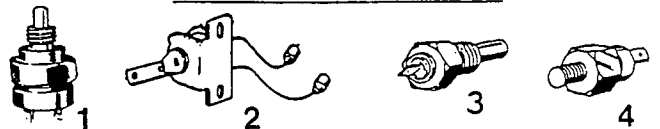

- L. 3533/170 - Contacteur de sécurité
- L. 1425/168 - Contacteur 5500, 6500, 7500, 8500 (3302937) 12500, 14500
- L. 1424/104 - Contacteur de stop
M. 1877731 - Sonde de température (1825118)
- M. 1877721/A - Contacteur pression d'huile (1423895) 6500, 7500, 8500, 6550, 7550, 8550
L. 1423/896 - Contacteur pression d'huile 5500, 5830
L. 2848/062 - Contacteur pression d'huile 10000, 12500, 13000, 14500

MANOMETRES HUILE ET TEMPERATURE

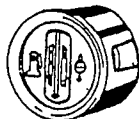
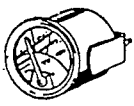

L. 1822/732 - Manomètre température
 L. 973/085 - Manomètre pression huile 9500
 M. 3305408 - Combiné temp./carburant (1825117) Tous tracteurs

BOUGIE DE PRECHAUFFAGE

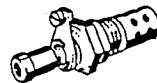

M. 1854050 - Tous moteurs PERKINS (2666103, 2666108)

INDICATEURS LUMINEUX



L. 1424/103 - Feux de route/clignotants
 L. 1825/362 - Pression huile/charge bat.

BOITE A FUSIBLES



L. 1424/118 - 5500, 6500, 7500, 8500, 9500 (1823288)
 L. 3300/568 - 6550 → 14500

INTERRUPTEURS ET CONTACTEUR

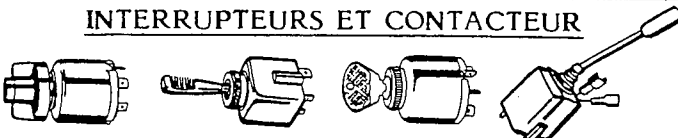

M. 1825360 - Interrupteur éclairage/avertisseur 5500, 6500, 7500, 8500
 L. 3300/530 - Idem, 6550, 7550, 8550, 5830, 6830, 7830, 8830
 L. 1425/878 - Idem, 12500, 14500
 M. 1424108 - Interrupteur des clignotants
 M. 1424109 - Contacteur à clef (PR/O/S/DEM)
 L. 3302/034 - Contacteur à clef (O/S/PR/DEM)
 M. 1825462 - Clef
 L. 3306/612 - Combiné clignotants/phares/avertisseur.

FLOTTEURS DE RESERVOIR

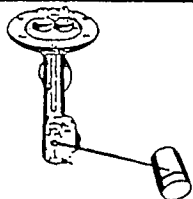

M. 1825031 - 5500, 6500, 7500, 8500
 L. 3301/628 - 6550, 7550, 8550, 10000
 L. 1425/614 - 12500, 14500

BOITES CLIGNOTANTES



L. 1808/481 - 5500 → 9500
 L. 3300/536 - 6550 → 14500

FILTRES A AIR

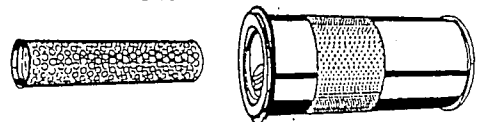

	INTERIEUR	PRINCIPAL
9500 (Base fermée)	-	M. 1420377
9500 (Base percée)	-	2248
10000, 12500	2466 (1093683)	2465 (1093682)
10000S, 13000	2466 (1093683)	TFA. 581 (3310355)
14500	TFA. 734 (1426450)	TFA. 732 (1426451)
13500	TFA. 767 (1096475)	TFA. 764 (1096473)

DURITES DE FILTRE A AIR

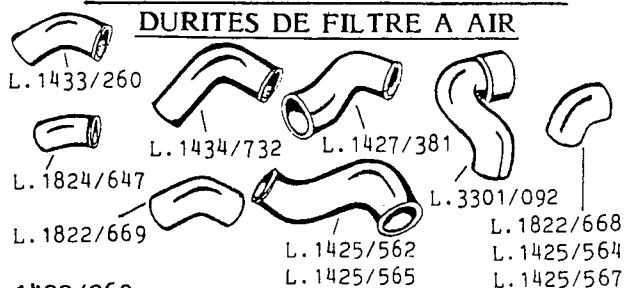

L. 1433/260	5500	L. 3301/092	10000
L. 1434/732	6500, 7500, 8500	L. 1425/562	12500
L. 1824/647	6550, 7550, 8550	L. 1425/564	
L. 1427/381	6550, 7550, 8550	L. 1425/565	14500
L. 1822/668	9500	L. 1425/567	
L. 1822/669			

CABLES DE COMMANDE DE L'EMBRAYAGE

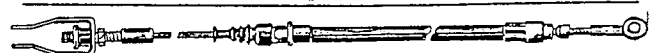

L. 1427/397 - Commande manuelle 6550, 7550
 L. 1427/398 - Commande par pédale 8550 et dérivés.

Non original replacements

FREINS A DISQUES SECS

- M. 183515 - Mécanisme complet (A) (3302698, 982047) Ø 178 mm.
- M. 1822606 - Mécanisme complet (A) (3300320) Ø 165 mm.
- M. 1810335 - Disque garni (9500) (1753117) Ø 178 mm.
- M. 1823112 - Disque garni (B) Ø 165 mm.
- L. 3302/699 - Disque garni (A) Ø 178 mm.
- M. 1423617 - Ø 165 mm. Jeu de 4 garnitures
- M. 840916K - Ø 178 mm. avec rivets
- M. 840/GV. 916 - Ø 178 mm. (Garnitures rainurées)
- M. 16779 - Bille Ø 3/4"
- M. 1005510 - Ressort

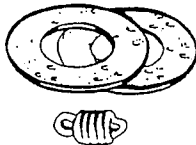
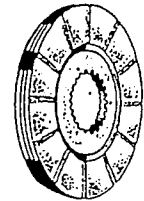
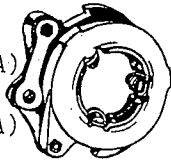

(A) Selon montage sur 5500, 6500, 7500, 8500, 6550, 7550, 8550 et 9500 (Ø 178)

FREINS SOUS HUILE

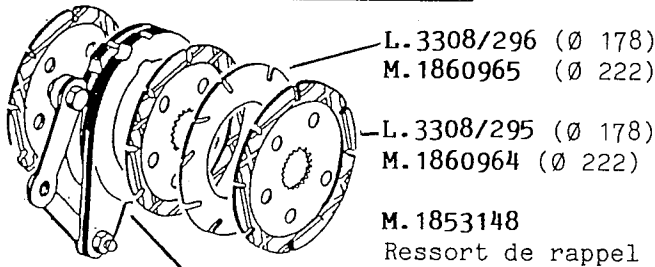

- L. 3308/296 (Ø 178)
- M. 1860965 (Ø 222)
- L. 3308/295 (Ø 178)
- M. 1860964 (Ø 222)
- M. 1853148 Ressort de rappel
- L. 3304/634 Mécanisme (Ø 178)
- 30/1860963 Mécanisme (Ø 222)
- Frein Ø 178 mm.: 5530 à 9880
- Frein Ø 222 mm.: 10000, 12500, 13000, 14500

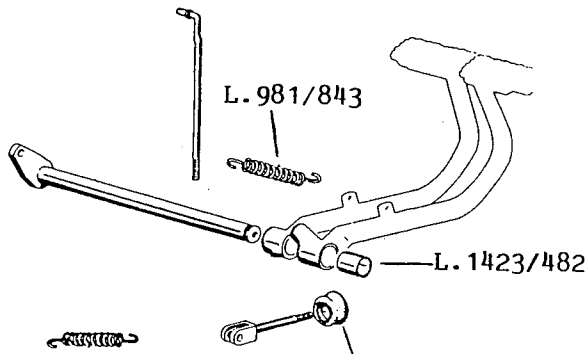

- L. 981/843
- L. 1423/482
- L. 974/717 Ressort de rappel (Disques)
- M. 183462 (Frein Ø 178)
- M. 1860959 (Frein Ø 222)

FREINS DE STATIONNEMENT

- L. 3302/355 - Disque Ø 142 (3/tract.) Sur 5530, 6530, 5830, 6830, 7830, 8830
- L. 3302/840 - Disque Ø 152 (4/tract.) Sur 10000, 12500, 13000, 14500
- L. 3302/353 - Segment (3 par tract.)
- L. 3302/354 - Segment (3 par tract.)

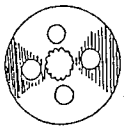

FREINS HYDRAULIQUES

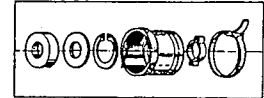
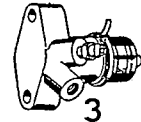
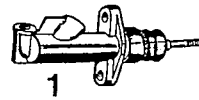

- 1. M. 1874957 - Maître cyl. Ø 17,8 | 12500
- 2. M. 1810596 - Jeu réparation | 14500
- 1. M. 1887957 - Maître cyl. (8550, liquide rose)
- 1. 30/3305623 - Maître cyl. | Série "80"
- 2. M. 1810687 - Jeu réparation
- 3. L. 785/625 - Cylindre | 6550, 7550, 8550, 10000,
- 4. L. 1810/573 - Jeu rép. | 12500, 13000, 14500

ACCESSOIRES DE RESERVOIR



- L. 1825/066 (A)
- L. 3300/019 (B)

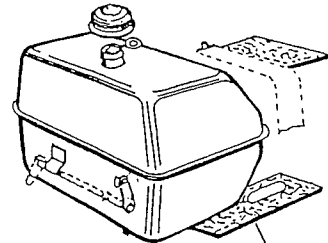

- L. 3310/087 (Tamis)

- L. 1825/070 (A)
- L. 973/036 (9500)

- L. 1825/071 (A)

- L. 1825/082 (7500, 8500)
- (A) 5500, 6500, 7500, 8500
- (B) 6550, 7550, 8550

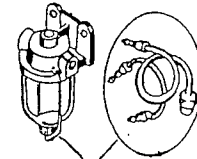

- L. 0011269, kit (Tous modèles)

ECHAPPEMENTS VERTICAUX

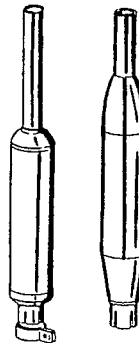

Voir le fascicule 1 pour d'autres modèles

- M. 880678 (Peint) | Du 5500
- L. 1427/799 (Emaillé) | au 8830

COMMANDE DES GAZ

- L. 1825/086

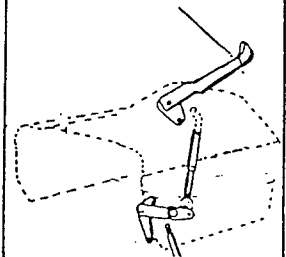

BOITE DE VITESSES

- L. 3300/965
- L. 1824/689
- L. 3305/098
- L. 975/086
- L. 361/031
- L. 3305/099
- (5500 → 8500, 5530 → 7530)

5500 → 8500
6550 → 8550

Non original replacements

DIRECTIONS (Manuelle et assistée)

L. 3300/424 (A,B,D) L. 1426/684 (A,D)
(3530018)

L. 3300/937 (D,C)

Kits de direction assistées voir page 7

L. 1424/232 (A,B)

L. 1425/492 (D)

L. 1809/696 (A,B,C)

M. 1810503 (A,B,C)
(Pour Orbitrol)

L. 011153
(Pour verins)

Voir "POMPES HYDRAULIQUES ET ACCESSOIRES", page LA-7

L. 1605/172 (A,B)

L. 1748/133 (A,B,C, 10000)

M. 1617826 (A,B,D) voir aussi page LA-8

(A) 5500 → 8500 (C) 9500
(B) 5830 → 8830 (D) 10000 → 14500

5500 → 8500
5550 → 8550
5830 → 8830

L. 1423/630

L. 1423/636

M. 1821234 (4 par tracteur)
Voir aussi page LA-8

L. 975/208

L. 392/060

L. 394/014 L. 339/394 L. 339/393

TRANSMISSION AVANT

(A) 5500,6500,7500,8500
(B) 6550,7550,8550
(C) 5530,6530,7530

L. 1423/675 (5500,5530)
L. 1423/674 (6500,7500)
L. 1423/967 (8500)
L. 1425/211 (12500,14500)

L. 3300/741 (5500,5830)
L. 3300/742 (6500,7500,6830,7830)
L. 3300/743 (8500,8830)
L. 1427/373 (6550,7550,8550)

L. 1824/119 (A,B,C)
L. 1425/213 (12500,14500)

L. 392/101 (B.E.)
L. 392/107 (Acier)

L. 1824/119 (A,B,C)
L. 1425/213 (12500,14500)
L. 339/583 (Bague)
L. 1427/376 (Palier)
L. 1820/418 (A,B)
L. 339/440 (A,B,C)

L. 1423/661 (5500,6500,6550)
L. 1423/568 (7500,8500,7550,8550)

L. 1423/668

L. 390/876 (A,B)

L. 1824/119 (A,B,C)
L. 1425/213 (12500,14500)
L. 339/583 (Bague)
L. 1427/376 (Palier)
L. 1820/418 (A,B)
L. 339/440 (A,B,C)

CROISILLONS (Pont avant)

L. 1423/444 (Ø 27x82) 5500 → 8500
L. 1422/823 (115x89x43) 8000, 8500, 9500
L. 1422/787 (130x104x49) 8000, 8500, 9500

PONT AVANT MOTEUR

L. 1823/560 (A)
L. 1427/449 (A,B)

L. 1424/401 (A)

L. 1823/572 (A,B)

L. 1823/575 (A)
L. 392/184 (A,B)

L. 1442/550 (A)
L. 1427/448 (A,B) L. 391/337 (A,B)
L. 1617/846 (E)

L. 395/527

L. 391/336 (A,B)

M. 1821234 (A,B)
M. 1824403 (E)
Voir aussi page LA-8

L. 1823/570 (A,B) L. 1823/571 (A,B)

L. 392/108 (A,B)

M. 1821234 (A,B)
M. 1824403 (E)
Voir aussi page LA-8

L. 1823/598 (A,B)

Non original replacements

MECANISMES ET DISQUES D'EMBRAYAGE «LUK» et «VALEO»

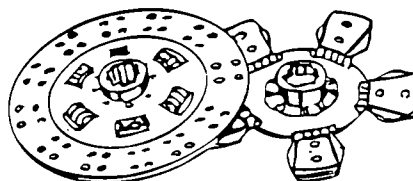
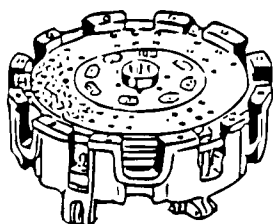

APPLICATIONS	EMBRAYAGES		DISQUES		BUTEES DE DEBRAYAGE	
	Ø	REF.CDE	Ø	REF.CDE		
4530, 4830 4860, 5500, 5530, 5830/C, 5840, 5860, 6030, 6040, 6060, 6500, 6530, 6550, 6830/C, 6840, 6880, 7500, 7530, 7550, 7830/C 8500, 8530, 8550, 8830 LUK ET VALEO INTERCHANGEABLE	280/280 6 doigts LUK	228 0003 15	280 (A)	328 0010 16 (LG) 14Z 35x40	M.1423473 50x94x21	
			280 (A)	328 0083 16 (LM) 10Z 22x25		L.1442/381 (PTO) 6204 2RS (RV)
	280/280 6 doigts LUK	228 0003 14	280 (B)	328 0010 14 (LG) 14Z 35x40		
			280 (A)	328 0083 16 (LM) 10Z 22x25		
	280/280 6 doigts VALEO	L.011084	280 (A)	M.1424123 (LG)(VZ) 14Z 35x40		
			280 (B)	M.1424149 (LG)(VZ) 14Z 35x40 OMG		
			280 (A)	M.1424135 (LM)(VZ) 10Z 22x25		
	R 6000 SUPER & DT 6500	280/280 diaphragme 3 doigts VALEO	L.1821/716	280 (B)	M.1424P/149 (LG) 14Z 35x40	
				280 (A)	L.1423/293 (LM) 10Z 22x25	
280 (A)				L.1423/291 (LG) 14Z 35X40		
R 6000	LANDINI		270 (A)	M.974962 (LG)(VZ) 10Z 46x56		
			270 (A)	M.974966 (LM)(VZ) 10Z 21x26		

- (A) Friction organique sans amiante
- (B) Friction céramétique
- (VZ) Version économique
- (RV) Roulement de volant

- (LG) Friction d'avancement côté BV, intégrée
- (LH) Friction d'avancement côté moteur, intégrée
- (LI) Friction prise de force côté moteur, intégrée
- (LK) Friction prise de force côté BV, intégrée
- (LM) Friction prise de force côté moteur, libre
- (LN) Friction d'avancement côté moteur, libre

Non original replacements

MECANISMES ET DISQUES D'EMBRAYAGE «LUK» et «VALEO»

APPLICATIONS	EMBRAYAGES		DISQUES		BUTEES DE DEBRAYAGE
	Ø	REF.CDE	Ø	REF.CDE	
6860, 6870, 7860, 7870, 7880, 8870, 8880, 9880	310/310 6 doigts LUK	231 0046 11	310 (B) 310 (A)	331 0133 11 (LG) 14Z 35x40 331 0134 16 (LM) 10Z 22x25	M.1423473 50x94x21 L.1442/381 (PTO) 6204 2RS (RV)
R 9500, R 9500 DT	310/310 diaphragme 3 doigts VALEO	L.1823/150	310 (B) 310 (A)	M.1423267 (LG) (VZ) 16Z 40x45 M.1423304 (LM) 13Z 23x29,5	L.1822/096 55x92x30
10000, 10000 S → 22900804	310/310 6 doigts LUK	231 0030 10	310 (B) 310 (A) 310 (A)	331 0096 10 (LG) 23Z 44x48 331 0097 16 (LM) 16Z 27x30 L.3301/234 (LM) (VZ) 16Z 27x30	30/3302143 55x92x32
10000, 10000 S 22900805 → , 12500, 13000, 14500	330/330 6 doigts LUK	233 0020 12	330 (B) 330 (A) 330 (A)	333 0045 10 (LG) 23Z 44x48 333 0019 16 (LM) 16Z 27x30 L.1426/390 (LM)(VZ) 16Z 27x30	M.1425227 55x92,5x30 L.392/191 (PTO)

**TABEAU DE CONVERSION
DES ANCIENNES REFERENCES TRACPIECES
Page LA-6, fascicule 3 (05/92)**

L. 3105/237	=	331 0133 11
L. 3301/230	=	331 0096 10
L. 3302/049	=	333 0045 10
L. 3303/137	=	233 0020 12
L. 3304/468	=	231 0030 10
L. 3305/233	=	331 0134 16
L. 3532/192	=	231 0046 11

- (A) Friction organique sans amiante
- (B) Friction céramétique
- (VZ) Version économique
- (RV) Roulement de volant

- (LG) Friction d'avancement côté BV, intégrée
- (LH) Friction d'avancement côté moteur, intégrée
- (LI) Friction prise de force côté moteur, intégrée
- (LK) Friction prise de force côté BV, intégrée
- (LM) Friction prise de force côté moteur, libre
- (LN) Friction d'avancement côté moteur, libre

Non original replacements

PIECES POUR MECANISME DU R.9500, 9500 DT

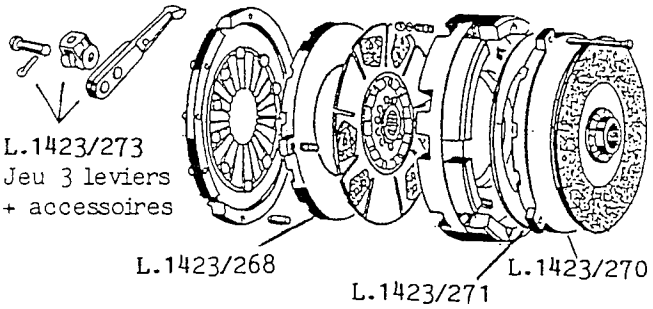

L.1423/273
Jeu 3 leviers
+ accessoires

L.1423/268

L.1423/271

L.1423/270

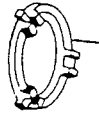
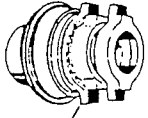

L.1423/286

L.1822/106 Complet
L.1822/096 Roulement

MECANISMES "LUK", "OMG" 280/280

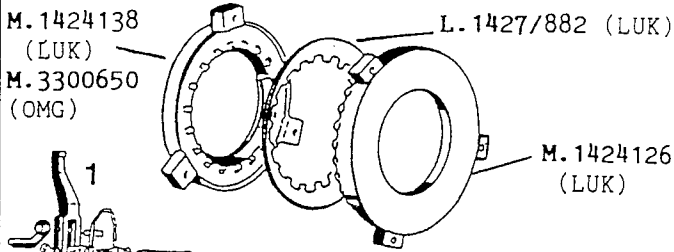

M.1424138
(LUK)
M.3300650
(OMG)

L.1427/882 (LUK)

M.1424126
(LUK)

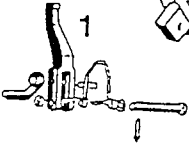

JEUX AVEC 3 LEVIERS (OMG 11")

M.3300647 - Jeu type 1

M.3300651 - Jeu type 2

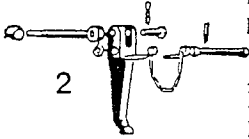

JEUX AVEC 3 LEVIERS (LUK 11")

LK.4800 - Avec leviers courts

LK.4700 - Avec leviers longs

COUPLE CONIQUE, REDUCTEURS, ARBRES DE ROUE

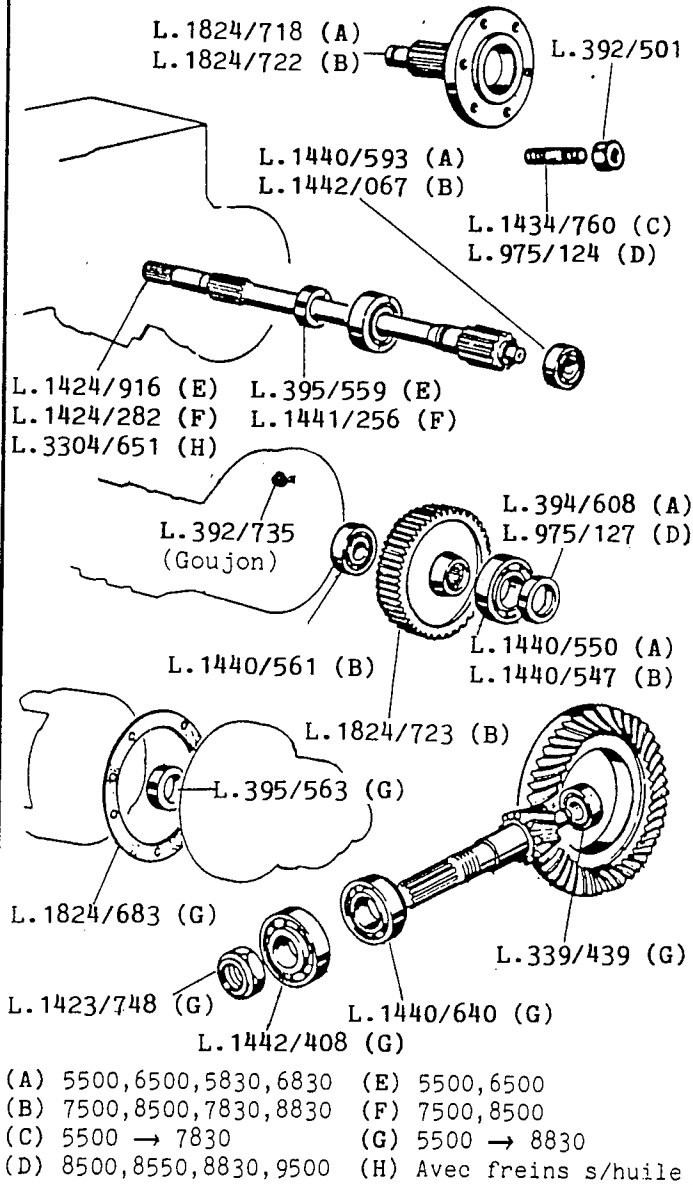

KITS DE DIRECTION ASSISTEE

Fournis avec tous accessoires.

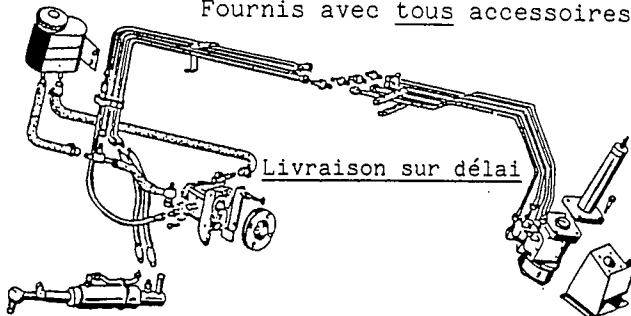

ADAPTABLES "CALZOKIT" :

DA.082 - 4500,5500,6500,7500 (supports non fournis)
DA.059 - 8000

AVEC SYSTEME HYDROSTATIQUE :

L.011432 - 5500
L.011420 - 5500 DT
L.011421 - 6500,7500,8500
L.011422 - 6500DT,7500DT,8500DT

DOCUMENTATION DETAILLEE
SUR DEMANDE

PRISES DE FORCE (*)

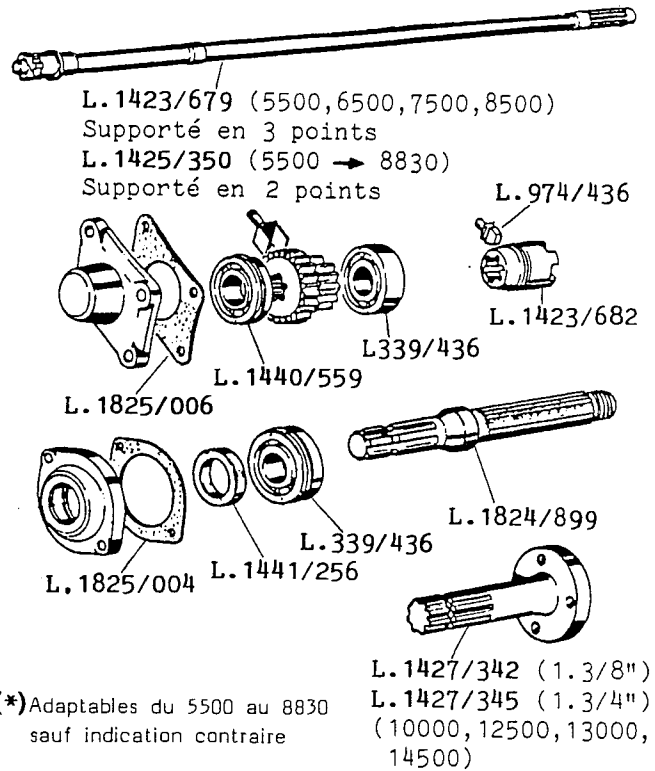

POMPES HYDRAULIQUES ET ACCESSOIRES

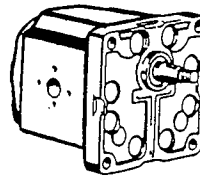

POMPES DE DIRECTION ASSISTEE

L.1424/599 (GR.2) - Avec soupape 5500 à 8500
31/1825210A (GR.2) - 6550 à 8550,5830 à 8830, 10000,12500,14500

POMPES DE RELEVAGE

31/1825210A (GR.2) - 5500,5830
M.1825212 (GR.2) - 6500 à 8500,6500 à 8550, 6830 à 8830
31/1824474A (GR.2) - 9500,5530,6530,7530
L.3301/295 (GR.3) - (22L/M) 10000,13000
L1425/495 (GR.3) - (26,5L/M) 12500,14500

KIT DE JOINTS POUR POMPE

L.1493/859 - Pour pompe 1825210

COMMANDES DE POMPES

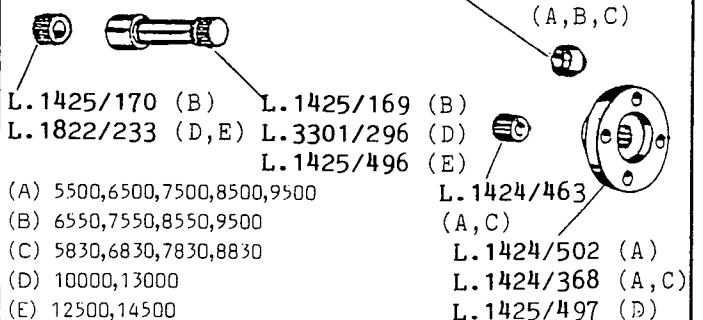

Non original replacements

RELEVAGE HYDRAULIQUE

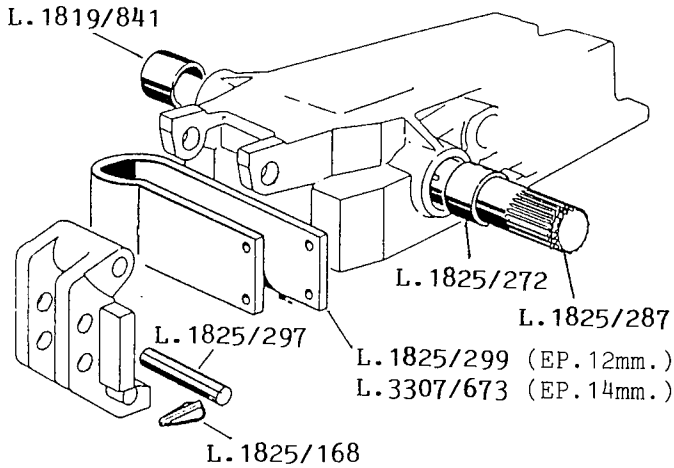

(Tous tracteurs, sauf séries 10000,12000).

TABLEAU DES ROTULES DE DIRECTION

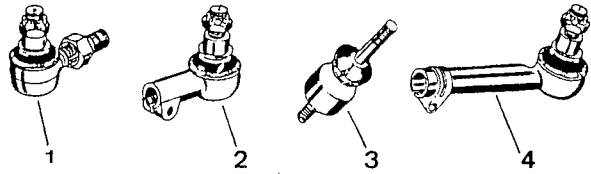

- 1. M. 1821234 - 5500, 6500, 7500, 8500, 6550, 7550
8550, 5830, 6830, 7830, 8830
M. 1824403 - 9500, 10000, 12500, 13000, 14500
L. 3426/773 - Fil. droit (renf.) | 9500, 10000, 12500
M. 1617829 - Fil. gauche | 13000, 14500
- 2. M. 1617826 - 5500, 6500, 7500, 8500, 6550, 7550
(3426660) 8550, 5830, 6830, 7830, 8830, 9500
10000, 13000
- 3. L. 3426/312 - 5860, 5870, 6060, 6860, 6870, 6880
7860, 7870, 7880, 8860, 8870, 8880
10000, 13000
L. 3426/255 - 14500
- 4. L. 3426/336 - 5860, 5870, 6060, 6860, 6870, 6880
7860, 7870, 7880, 8860, 9970, 8880
L. 3426/313 - 10000, 13000
L. 3426/276 - 14500

CARTOUCHES DE FILTRE HYDRAULIQUE

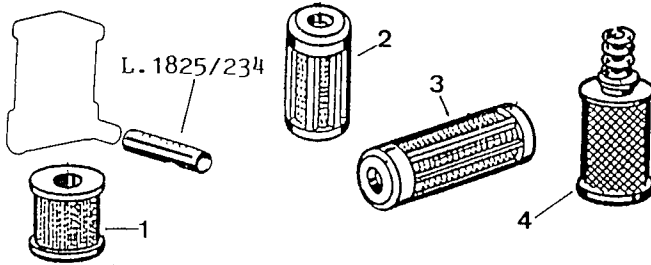

- 1. L. 974/535 - 9500, relevage
- 2. L. 1825/222 - 5500 → 8550, relevage
(3307250)
- 3. L. 1425/411 - Relevage | 10000, 12500
L. 1426/462 - Type court, blocage | 13000
L. 3302/055 - Type long, blocage | 14500
- 4. L. 1425/418 - Relevage 10000, 12500, 14500

ATTELAGE 3 POINT

(5500 → 8500, 6550 → 8550, 5830 → 8830)

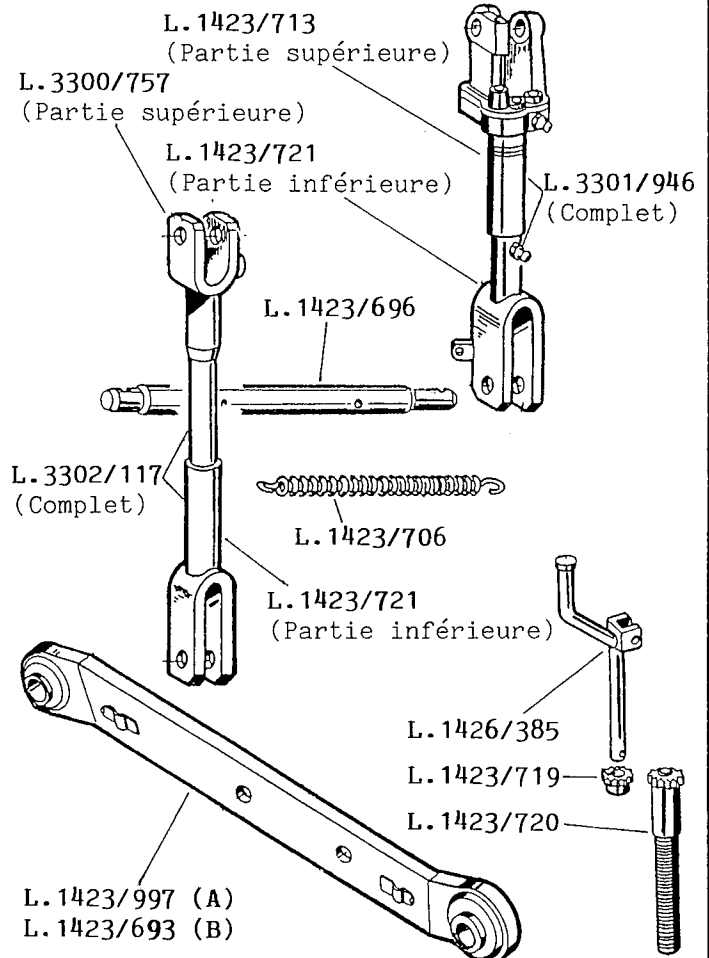

(A) - 5500, 5830, 6500, 6550, 6830
(B) - 7500, 7550, 7830, 8500, 8550, 8830

**BARRE FLEXIBLE DE CONTROLE
(10000, 12500, 13000, 14500)**

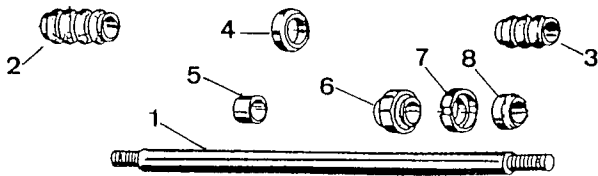

- 1. L. 1425/330
- 2. L. 1425/338
- 3. L. 1425/347
- 4. L. 1426/683
- 5. L. 1425/344
- 6. L. 392/283
- 7. L. 1427/441
- 8. L. 392/210

**JEUX DE REPARATION POUR
VERIN D'ASSISTANCE**

- L. 1606/591 - 10000, 13000
- L. 1606/592 - 12500, 14500

Non original replacements

ATTELAGE 3 POINT
(10000,10000 S,13000)

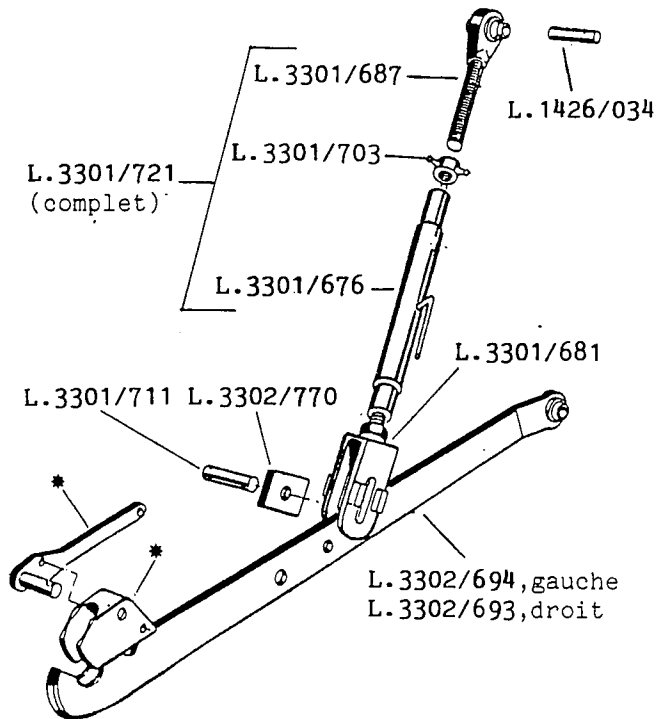

* Voir fascicule 1 (Pièces attelage C.B.M.)

AXES ET PIVOTS D'ATTELAGE
(SAUF 10000,12500,13000,14500)

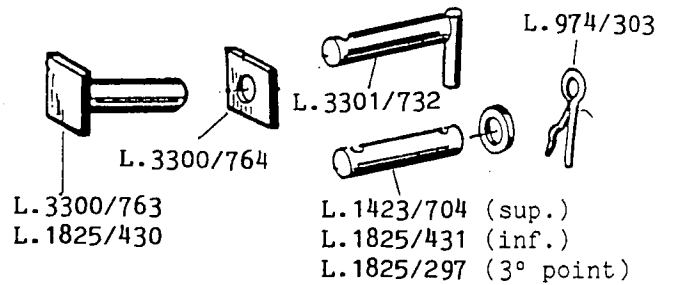

STABILISATEURS A CHAINE

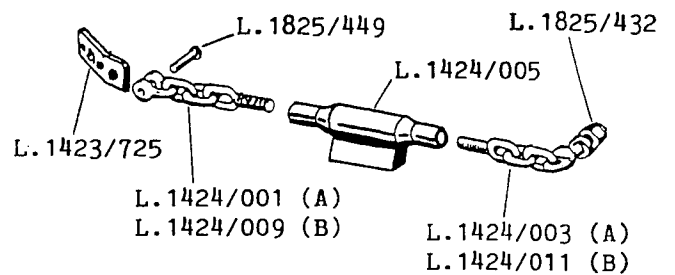

ENSEMBLES COMPLETS :

- L. 1424/000 (A)
- L. 1424/008 (B)
- M. 1824418 - 9500
- (A) 5500,6500,6550,5830,6830
- (B) 7500→8830

ATTELAGE 3 POINT
(12500,14500)

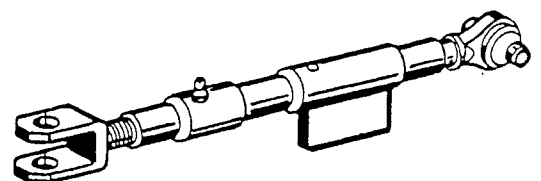
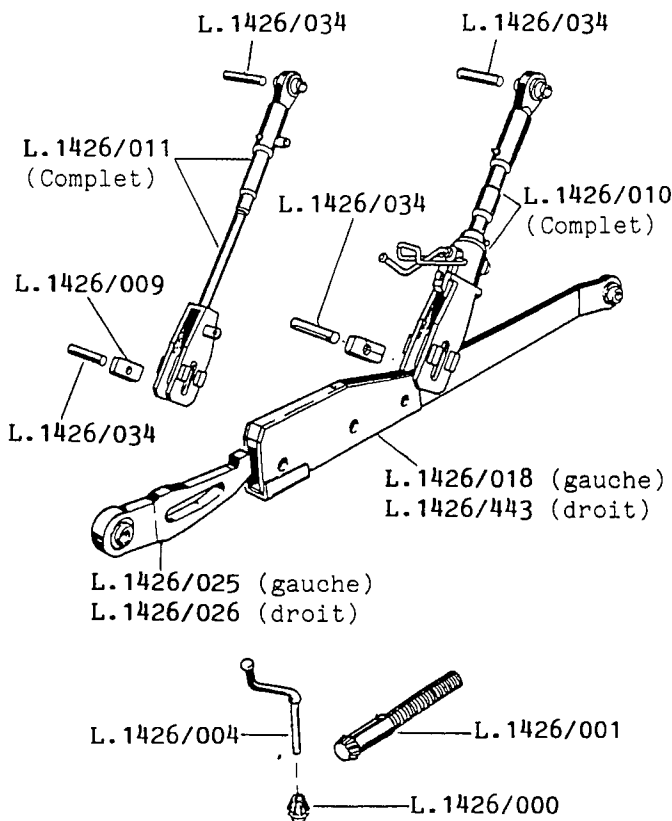

Voir à la section "ATTELAGE 3 POINTS" du fascicule 1, les types appropriés

BARRES DE POUSSEE DU 3° POINT

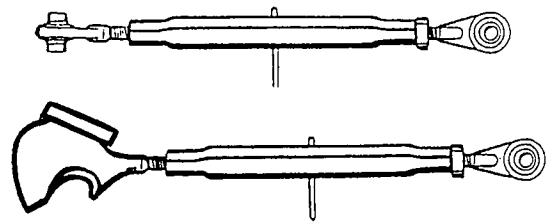

Voir à la section "ATTELAGE 3 POINTS" du fascicule 1, les types appropriés

BARRE D'ATTELAGE

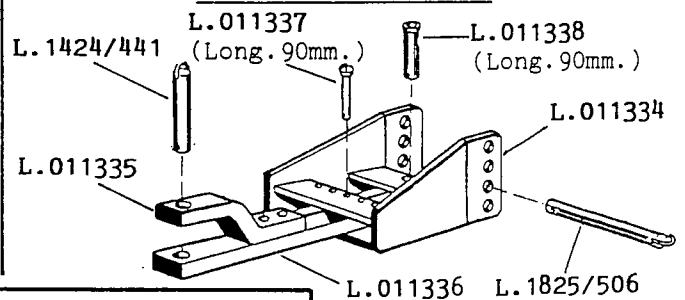

Non original replacements

KIT D'ASSISTANCE RELEVAGE (à 2 verins)

5500, 6500, 7500, 8500, 6550, 7550, 8550,
5830, 6830, 7830 et 8830.

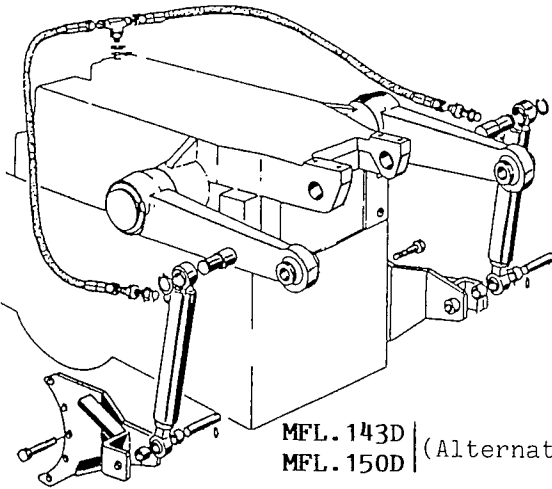

MFL. 143D
MFL. 150D (Alternatifs)

KITS COMPLETS DE DISTRIBUTEURS HYDRAULIQUES

NOUVEAU MODELE - Fixation par 3 goujons
Kits prêts au montage comprenant 1,2 ou 3 éléments, tuyauteries, console, coupleurs.

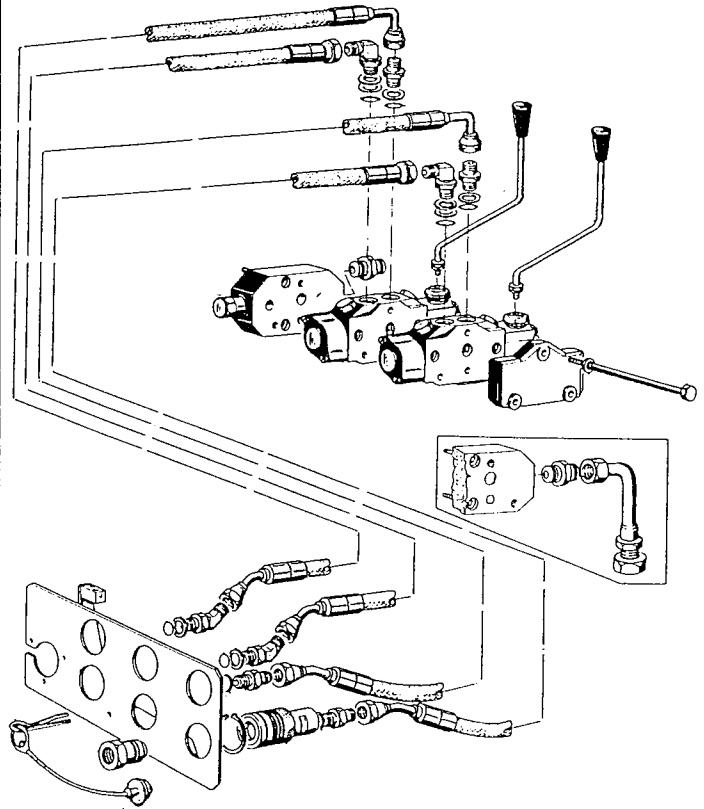

DISTRIBUTEURS HYDRAULIQUES

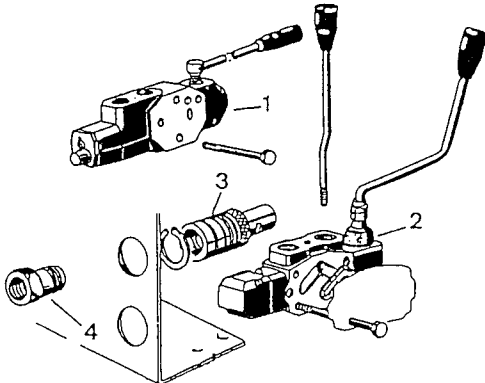

- 1 - L.1426/921 - Élément double effet, (fixation 2 goujons) convertible simple effet. 5500,6500,7500,8500,8550
- 2 - L.3305/824 - Élément double effet, (fixation 4 goujons) convertible simple effet. 6550,7550,8550,5830,6830,7830,8830. (Avec levier droit pour 6550, 7550 et 8550)
- NI - L.3305/823 - Élément à position flottante. (Pour montage "TILL" d'origine)
- 3 - M.1610606 - Coupleur femelle, type M-F.
- 4 - M.1610607 - Coupleur mâle, type M-F.

DISTRIBUTEURS "TILL" A ELEMENTS SEPARES

- MFL.30000 - Distributeur avec 1 élément 6550,7550,8550,5830,6830,7830 et 8830.
- MFL.30001 - Distributeur avec 1 élément 5500,6500,7500 et 8500.
- HSV.6 - Élément supplémentaire.

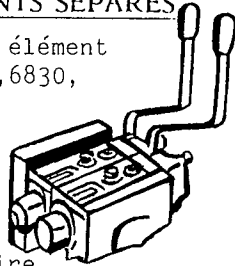

Equipés d'une plaque interface pour montage sur le couvercle du relevage "LANDINI". Pression de travail : 300 bar
Débit: 45 L/M.
De 1 à 2 éléments assemblés, réglables individuellement en simple ou double effet. Leviers disposables en 3 positions crantées ou en rappel automatique.

- LO.11327 - Kit complet, avec 1 élément
- LO.11328 - " " " 2 éléments
- LO.11329 - " " " 3 éléments

Adaptables sur 5500,7500,8500 - 6550, 7550,8550 - 5830,6830,7830,8830

ATTENTION : pour les tracteurs récents, nous consulter pour les distributeurs "TILL" montés d'origine sous les références 3533512M91, 3534904M91 et 3534905M91

TRACPIECES

N°1

AU SERVICE EXCLUSIF

DES MARCHANDS - REPARATEURS

DE TRACTEURS

Non original replacements



PHARES (gauche ou droit)
(5500,6500,7500,8500,9500)

M.1423852 - Jusque fin 1979
(140 x 140 x 93)
M.1424327 - Glace pour dito
L.3301/298 - 2ème modèle
(140 x 140 x 112)
L.3310/313 - Glace pour dito

(Sans lampe)

GROUPES OPTIQUES (sans lampe)

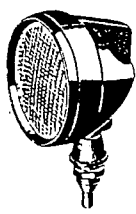

L.3300/524 - 6550,7550,8550
(3302340)
L.3305/625 - Ø 136 montage
"SATURNUS"
(nouvelles gammes)
L.1425/874 - Rectangulaire
(12500,14500)



PHARES DE TRAVAIL

M.1423870 (Ø 118)
(Lampe 35/50W)
M.1824335 - Glace pour dito
M.1678582 (Ø 142)
(Lampe 55W/H3)
M.1678583 - Optique pour dito

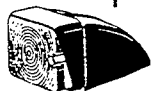
FEUX AVANTS (selon montages)

1. M.1424107 - Gauche ou droit (Glace : M.1424346)	5500→9500		
2. M.1425884 - Droit (Glace : M.1426605)	6550→8550 5530→8830		
M.1425883 - Gauche (Glace : M.1426603)	10000 12500		
3. L.3303/979 - Droit (Glace : M.3310292)	13000 14500		
L.3303/978 - Gauche (Glace : M.3310292)	Selon équip.		

FEUX ARRIERES (selon montages)

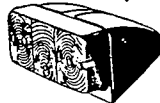
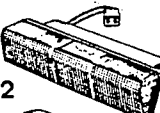
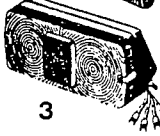
1. M.1424105 - Droit (Glace : M.1424354)	5500,6500 7500,8500	
M.1424106 - Gauche (Glace : M.1424357)	9500	
2. M.1425886 - Droit (Glace : M.1426609)	6550→8550 5530→8830	
M.1425885 - Gauche (Glace : M.1426607)	10000 12500	
3. L.3303/982 - Droit (Glace : L.3310/307)	13000 14500	
L.3303/980 - Gauche (Glace : L.3310/307)	Selon équip.	

CUVETTES AVEC GLACE POUR RETROVISEURS

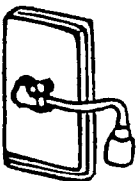

L.1427/251 - 354 x 169 mm.
L.3301/568 - 237 x 180 mm.
(sans bras)

ACCESSOIRES DE CABINE

ESSUIE-GLACES

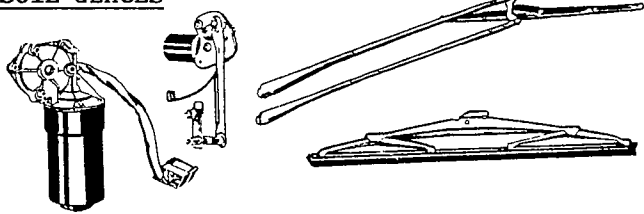

L.1427/013 - Mot.1° type (5500,6500,7500,8500)
L.3301/889 - Mot.2° type (6550→12500)
L.1427/023 - Balai (5500→8500)
L.3301/898 - Balai (6550→12500)
L.050053 - Kit leviers/balai + accessoires
(3301897/98) (6550→12500)

JEUX DE MARQUES AUTOCOLLANTES



L.1424/5500 (5500)
L.1424/6500 (6500)
L.1424/7500 (7500)



TELERUPTEURS

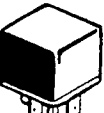

L.3303/312 - Fonct. continu 12V/20A
L.3306/230 - Fonct. non cont. 12V/20A

SERRURES **CHARNIERES** **POIGNEE**

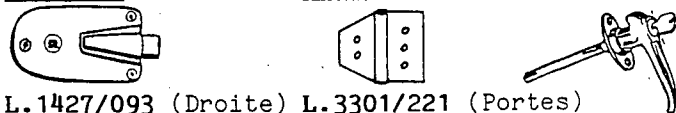

L.1427/093 (Droite) L.3301/221 (Portes)
L.1427/094 (Gauche) L.3301/222 (arrière) 6734

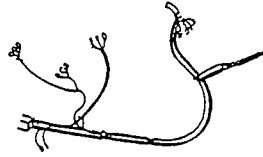

L.1425/053
L.1424/111
Faisceau
(5500 8500)



L.1424/104
Contacteur de stop
(Tous tracteurs)

ETAIS A GAZ



30/3301920 - Course 310/500. Vitre arr. | 6550 et
M.1873903 - Course 290/500. " " | séries
(3384671) | suivantes

M.3303021 - Course 145/210. Toit

L.1427/130 - Vitre arr. | 5500,6500,7500,8500
L.1427/157 - Toit | Cabines "SIAC"

AMORTISSEUR DE CABINE

L.1425/984 - 5500 à 12500



TABLEAUX DE SIGNALISATION



L.3307/232

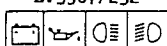

L.3307/233

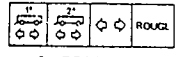

Non original replacements

JOINTS ET POCHETTES DE JOINTS POUR MOTEURS

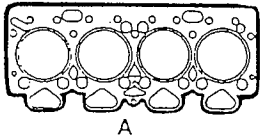

A

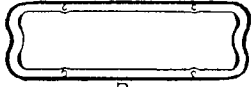

B

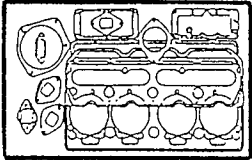

C = Pochette rôdage

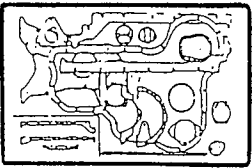

D = Pochette complémentaire
(E) Avec bourrage tressé
(F) Avec bague d'étanchéité

MOTEURS	A CULASSE	B C/SOUPAPES	C RODAGE	D COMPLEMENTAIRE
3.152	P.3681/2122	P.0490491	P.83398	P.85000
3.152D	P.3681/2127	P.3681/1115	P.82886	P.82887 (E) P.94422 (F)
4.203	-	-	P.83393	P.83373
4.203D	P.3681/2126	P.3681/1112	P.82907	P.82908 (E) P.83451 (F)
4.212				
4.236	P.3681/2341	P.3681/1114	P.82890	P.92440
4.248				
6A.354-1	P.3681/2547	-	30/P.50026P	30/P.50024P
6A.354-4	P.3681/2613	P.3681/1443	30/P.50033	30/P.50022B
T6.354-4	P.3681/2613	P.3681/1443	30/P.50034	30/P.50002
T6.354-1	P.3681/2547	P.3681/1443	30/P.50026P	30/P.50024P

REFERENCES INTERCHANGEABLES

68036	= P.83451	U5LB.0012	= P.85000
3681E006	= P.3681/2127	U5LB.0016	= P.92440
36812132	= P.3681/1114	U5LT.0012	= P.83398
36812136	= P.3681/2122	U5LT.0013	= P.82886
36812138	= P.3681/2126	U5LT.0015	= P.82890
36812349	= P.3681/2341	U5LT.0024	= 30/P.50024P
U5LB.0011	= P.94422	U5LT.0038	= P.82886

NOUS SOMMES

N°1

DU PAYS POUR :

LES PIECES ADAPTABLES COURANTES ...
LES COMPOSANTS HYDRAULIQUES ...
LES ACCESSOIRES ...

Plus de 30 ans d'activité nous a permis de composer un programme UNIQUE EN SON GENRE, vous proposant des articles d'usage journalier aux meilleurs prix.

CHOISISSEZ

TRACPIECES

pour **Un service sûr**
et sans contraintes ...



CES GRANDES MARQUES SONT DANS NOTRE PROGRAMME COURANT...

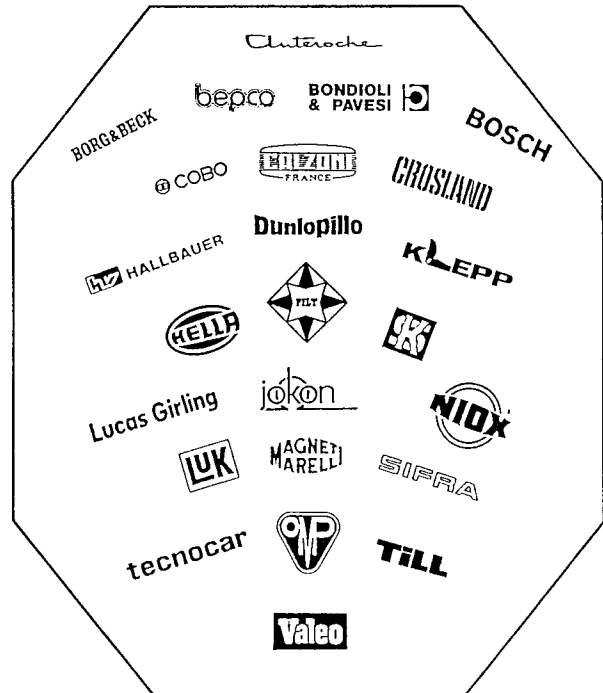

Non original replacements